

# Sine Rodless Cylinder

## REA/REB Series

(Maximum speed: 300 mm/s) (Maximum speed: 600 mm/s)

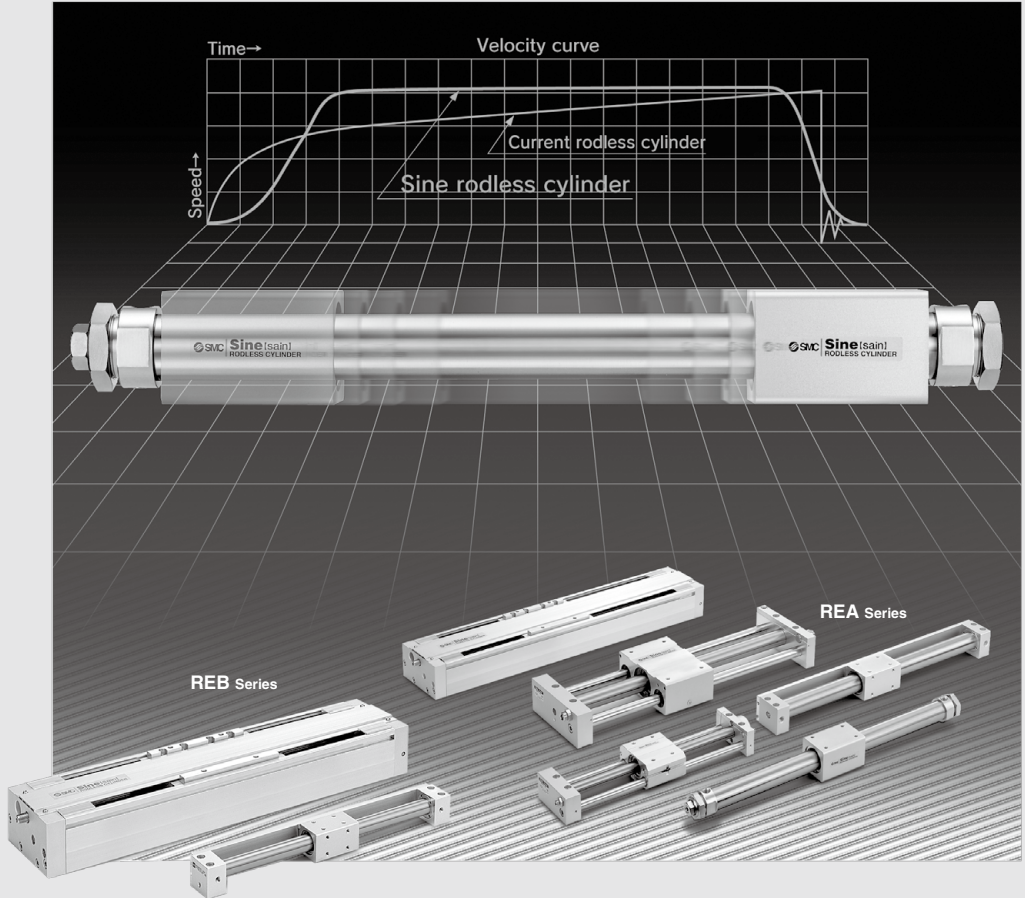

REA

REB

REC

Smooth

Low Speed

MQ

RHC

RZQ

### REA Series (300 mm/s)

Guide type	Model	Page
Basic type	REA	P. 21
Direct mount type	REAR	P. 29
Slider type (Slide bearing)	REAS	P. 41
Slider type (Ball bushing bearing)	REAL	P. 55
Linear guide type (Single axis)	REAH	P. 69
Linear guide type (Double axis)	REAHT	P. 69

### REB Series (600 mm/s)

Guide type	Model	Page
Direct mount type	REBR	P. 85
Linear guide type (Single axis)	REBH	P. 97
Linear guide type (Double axis)	REBHT	P. 97

D-□

-X□

# Allows rapid transfer of impact

Throughput dramatically increased  
(Maximum speed: **600** mm/s)

REB series introduced with a maximum speed of 600 mm/s. Compared with the previous type (REA series: 300 mm/s), the tact time can be shortened by approximately 1/2.

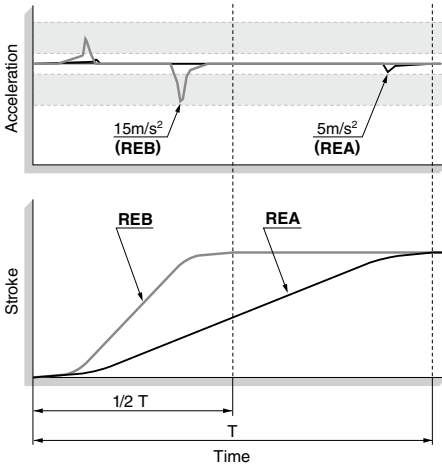

Smooth acceleration & deceleration at 5

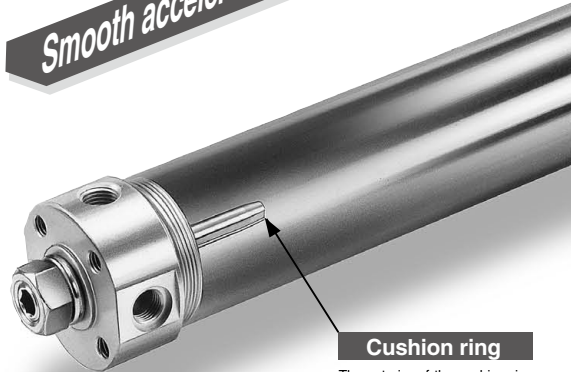

### Cushion ring

The exterior of the cushion ring is provided with a variable throttle groove in its longitudinal direction.

## Acceleration ranges

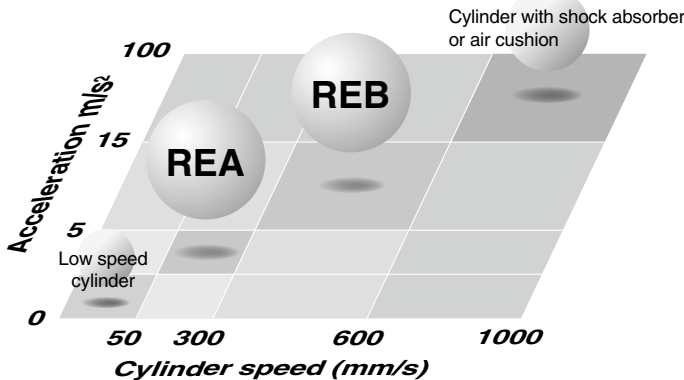

### Series Variations

#### REA Series (300 mm/s)

Guide type	Base cylinder	Model
Basic type	CY3B	REA
Direct mount type	CY3R	REAR
Slider type (Slide bearing)	CY1S	REAS
Slider type (Ball bushing bearing)	CY1L	REAL
Linear guide type (Single axis)	CY1H	REAH
Linear guide type (Double axis)	CY1HT	REAHT

# sensitive workpieces

Sine rodless cylinder  
**REA/REB Series**  
 Maximum speed (300 mm/s) Maximum speed (600 mm/s)

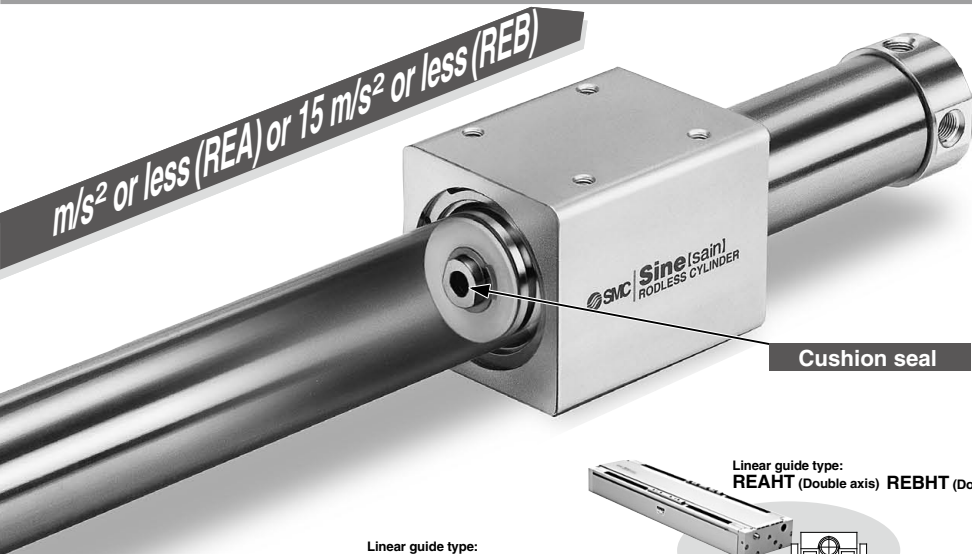

- REA
- REB
- REC
- Smooth
- Low Speed
- MQ
- RHC
- RZQ

High

Accuracy

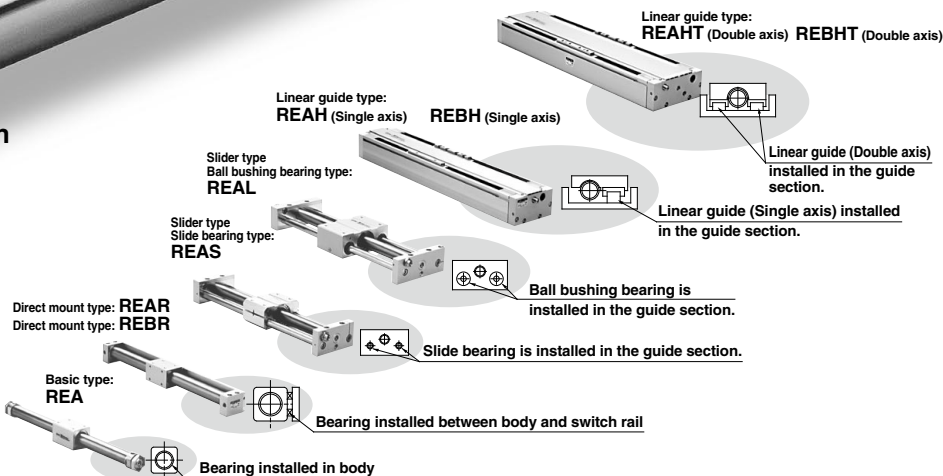

Allowable moment ▶ Large





## REB Series (600 mm/s)

Bore size							
10	15	20	25	32	40	50	63
			●	●	●	●	●
●	●	●	●	●	●	●	●
●	●	●	●	●	●	●	●
●	●	●	●	●	●	●	●
●	●	●	●	●	●	●	●
●	●	●	●	●	●	●	●

Guide type	Base cylinder	Model	Bore size							
			10	15	20	25	32	40	50	63
Direct mount type	CY3R	<b>REBR</b>	●	●	●	●	●	●	●	●
Linear guide type (Single axis)	CY1H	<b>REBH</b>	●	●	●	●	●	●	●	●
Linear guide type (Double axis)	CY1HT	<b>REBHT</b>	●	●	●	●	●	●	●	●

- D-□
- X□

# REA/REAR/REBR/REAS/REAL/REAH/REBH Series Model Selection Criteria

Model Selection Criteria	Recommended Cylinder			
	Appearance		Features	
<ul style="list-style-type: none"> <li>When many different types of guides are used</li> <li>When a long stroke is necessary</li> </ul>	Guide non-integrated type	<b>REA Series</b> Size: $\phi 25$ , $\phi 32$ , $\phi 40$ , $\phi 50$ , $\phi 63$ 	<ul style="list-style-type: none"> <li>Wide variations from <math>\phi 25</math> to <math>\phi 63</math>.</li> </ul>	<ul style="list-style-type: none"> <li>Long strokes available.</li> </ul>
<ul style="list-style-type: none"> <li>When many different types of guides are used</li> <li>When auto switches are added to the basic type</li> <li>When used without a guide for a light load</li> <li>When space is very limited</li> </ul>		<b>REAR Series</b> Size: $\phi 10$ , $\phi 15$ , $\phi 20$ , $\phi 25$ , $\phi 32$ , $\phi 40$ <b>REBR Series</b> Size: $\phi 15$ , $\phi 25$ , $\phi 32$ 	<ul style="list-style-type: none"> <li>Choice of the maximum speed of 300 mm/s or 600 mm/s is available.</li> </ul>	<ul style="list-style-type: none"> <li>Cylinder can be directly mounted.</li> <li>Auto switch capable, with no cylinder lurching.</li> <li>Rotation can be stopped within an allowable range.</li> <li>Compact external dimensions</li> <li>Mounting can be performed from the top or one side.</li> </ul>
<ul style="list-style-type: none"> <li>To ensure a permanent path</li> <li>When used for general transfer operations</li> </ul>	Guide integrated type	<b>REAS Series</b> Size: $\phi 10$ , $\phi 15$ , $\phi 20$ , $\phi 25$ , $\phi 32$ , $\phi 40$ 	<ul style="list-style-type: none"> <li>A load can be carried directly by the guide integrated type.</li> <li>The centralized piping type allows concentration of piping on one side plate.</li> <li>Auto switch capable.</li> <li>Choice of the maximum speed of 300 mm/s or 600 mm/s is available. (RECH/Linear guide type)</li> </ul>	<ul style="list-style-type: none"> <li>Smooth operation is made possible by using special slide bearings.</li> </ul>
<ul style="list-style-type: none"> <li>To ensure a permanent path</li> <li>When smoother operation is required, even with an offset load</li> </ul>		<b>REAL Series</b> Size: $\phi 10$ , $\phi 15$ , $\phi 20$ , $\phi 25$ , $\phi 32$ , $\phi 40$ 		<ul style="list-style-type: none"> <li>Stable operation is possible, even with an offset load, by using ball bushings.</li> </ul>
<ul style="list-style-type: none"> <li>To ensure a permanent path</li> <li>When a large load, large moment is required</li> <li>When used for pick-and-place operations, etc.</li> </ul>		<b>REAH Series</b> Size: $\phi 10$ , $\phi 15$ , $\phi 20$ , $\phi 25$ , $\phi 32$ <b>REBH Series</b> Size: $\phi 15$ , $\phi 25$ , $\phi 32$ 		<ul style="list-style-type: none"> <li>The use of a linear guide facilitates a large load, large moment.</li> <li>Mounting freedom is improved by providing T-slots on the mounting surfaces.</li> <li>A top cover mounted over the sliding parts of the cylinder prevents scratches and damage, etc.</li> </ul>



# REA/REB Series Specific Product Precautions

Be sure to read this before handling the products. Refer to back page 50 for Safety Instructions and pages 3 to 12 for Actuator and Auto Switch Precautions.

## Disassembly and Maintenance

### Warning

1. Use caution as the attractive force of the magnets is very strong.

When removing the external slider and piston slider from the cylinder tube for maintenance, etc., handle with caution, since the magnets installed in each slider have a very strong attractive force.

### Caution

1. Use caution when removing the external slider, as the piston slider will be directly attracted to it.

When removing the external slider or piston slider from the cylinder tube, first force the sliders out of their magnetically coupled positions, and then remove them individually when there is no longer any holding force. If they are removed while still magnetically coupled, they will be directly attracted to one another and will not come apart.

2. Do not disassemble the magnetic components (piston slider, external slider).

This can cause a loss of holding force and malfunction.

3. When disassembling to replace the seals and wear ring, refer to the separate disassembly instructions.

4. Use caution to the direction of the external slider and the piston slider.

Since the external slider and piston slider are directional for size  $\phi 10$ , refer to the figures below when performing disassembly or maintenance. Put the external slider and piston slider together, and insert the piston slider into the cylinder tube so that they will have the correct positional relationship as shown in Fig. (1). If they align as shown in Fig. (2), reinsert the piston slider only, after turning it around  $180^\circ$ . If the direction is not correct, it will be impossible to obtain the specified holding force.

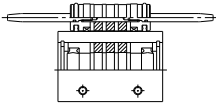

Fig. (1) Correct position

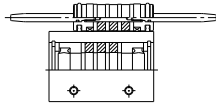

Fig. (2) Incorrect position

5. During disassembly, use caution in handling the cushion ring.

The cushion ring is a precision part, and any deformation, etc., can cause malfunction or poor performance.

## Speed Adjustment

### Caution

1. SMC's "throttle" type speed controllers (AS series) are recommended for speed adjustment. (Refer to Table (3).)

Table (3) Recommended Speed Controller

Bore size (mm)	Model		
	Elbow type	Straight type	In-line type
10	AS1201F-M5-04-X214	AS1301F-M5-04-X214	AS1001F-04-X214
15	AS1201F-M5-04-X214	AS1301F-M5-04-X214	AS1001F-04-X214
20	AS2201F-01-06-X214	AS2301F-01-06-X214	AS2001F-06-X214
25	AS2201F-01-06-X214	AS2301F-01-06-X214	AS2001F-06-X214
32	AS2201F-01-06-X214	AS2301F-01-06-X214	AS2001F-06-X214
40	AS2201F-02-06-X214	AS2301F-02-06-X214	AS2001F-06-X214
50	AS3201F-02-08-X214	AS3301F-02-08-X214	AS3001F-08-X214
63	AS3201F-02-08-X214	AS3301F-02-08-X214	AS3001F-08-X214

2. Speed adjustment is possible with meter-in/meter-out type speed controllers, but it may not be possible to obtain the cushion effect (smooth start-up, soft stop).

3. In the case of other than horizontal mounting, it is recommended that the system have a reduced pressure supply circuit installed at its lower side. (This is also effective as a countermeasure against start-up delay on an upward stroke, and for air conservation.)

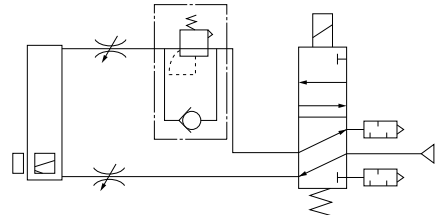

Lower-side reduced pressure supply circuit

## Adjustment of Cushion Effect (Smooth start-up, Soft stop)

### Caution

1. The cushion cannot be adjusted.

There is no cushion needle adjustment of the kind found on current cushion mechanisms.

REA

REB

REC

Smooth

Low Speed

MQ

RHC

RZQ

D-□

-X□



# Basic Type

## *REA Series*

ø25, ø32, ø40, ø50, ø63



REA

REB

REC

Smooth

Low  
Speed

MQ

RHC

RZQ

D-□

-X□

# REA Series Model Selection

**F<sub>n</sub>**: Allowable driving force (N)  
**P<sub>v</sub>**: Maximum operating pressure for vertical operation (MPa)  
**W<sub>max</sub>**: Maximum connection fitting mass (kg)  
**W<sub>v</sub>**: Allowable load mass for vertical operation (kg)

**Operating Conditions**

- W: Load mass (kg)
- W<sub>a</sub>: Connection fitting mass (kg)
- μ: Guide's coefficient of friction
- L<sub>o</sub>: Distance from cylinder shaft center to workpiece point of application (cm)
- Mode of operation (horizontal, inclined, vertical)
- P: Operating pressure (MPa)
- U: Maximum speed (mm/s)
- Stroke (mm)

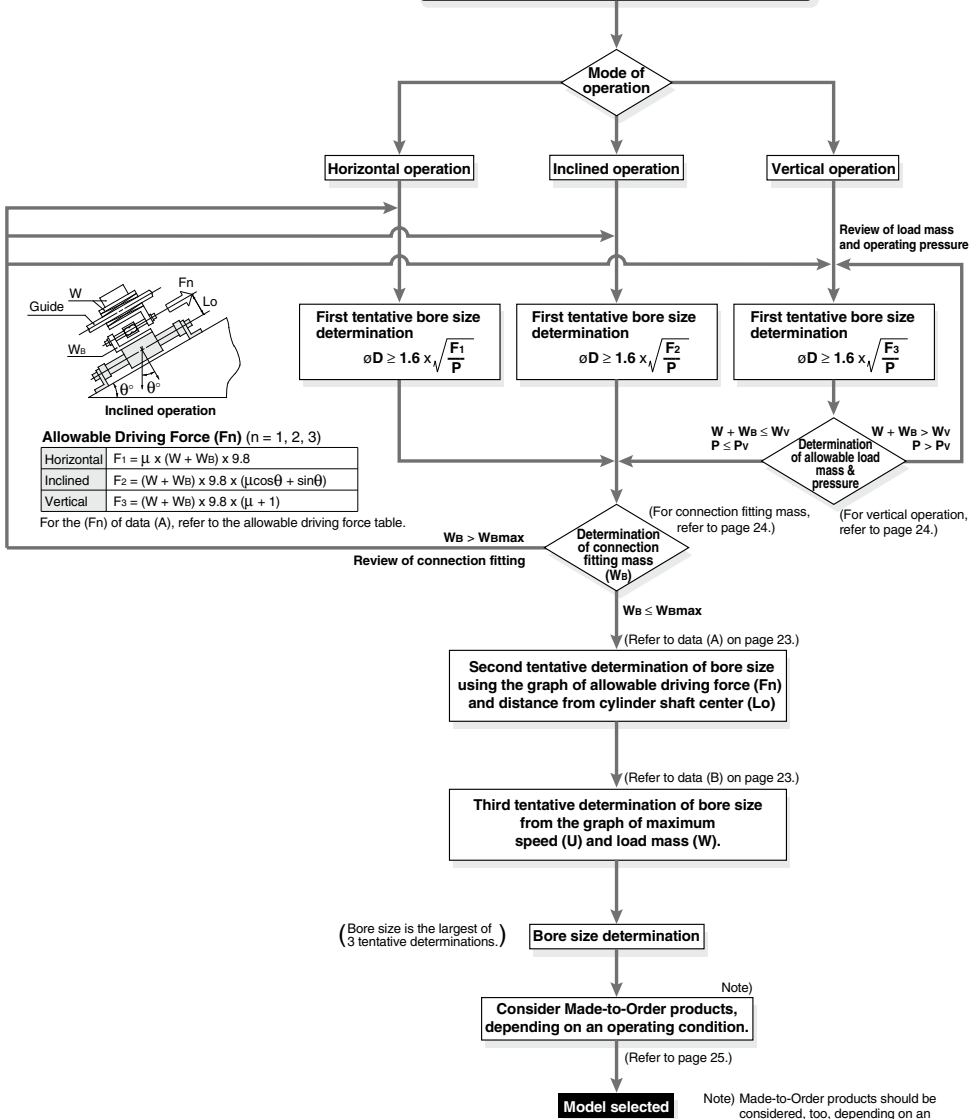



**Caution on Design 1**

**Selection Method**

**Selection Procedures**

1. Find the drive resisting force  $F_n$  (N) when moving the load horizontally.
2. Find the distance  $L_0$  (cm) from the point of the load where driving force is applied, to the center of the cylinder shaft.
3. Select a bore size from  $L_0$  and  $F_n$  in Data (A).

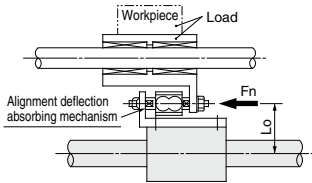

<Data (A): Distance from Cylinder Shaft Center — Allowable Driving Capacity>

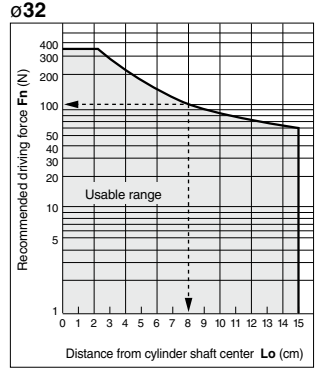
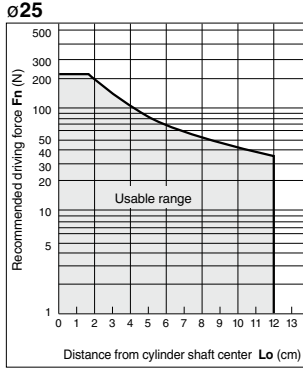

**Selection Example**

Given a load drive resisting force of  $F_n = 100$  (N) and a distance from the cylinder shaft center to the load application point of  $L_0 = 8$  cm, find the intersection point by extending upward from the horizontal axis of data (A) where the distance from the shaft center is 8 cm, and then extending to the side, find the allowable driving force on the vertical axis. Models suitable to satisfy the requirement of 100 (N) are **REA32** or **REA40**.

\* Distance from cylinder shaft center,  $L_0$ , is the moment working point between the cylinder and the load.

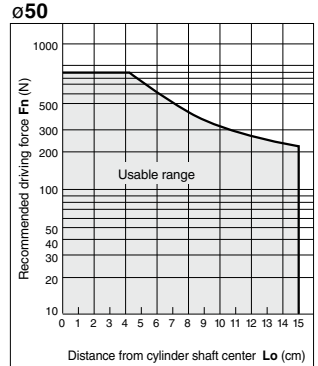
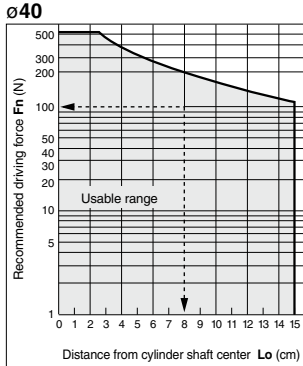

<Data (B): Maximum Speed — Load Mass Chart>

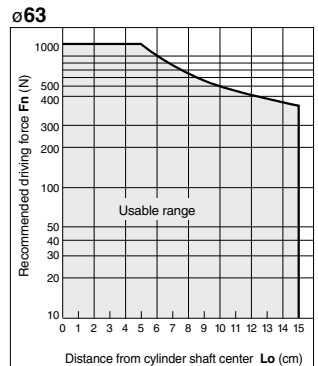
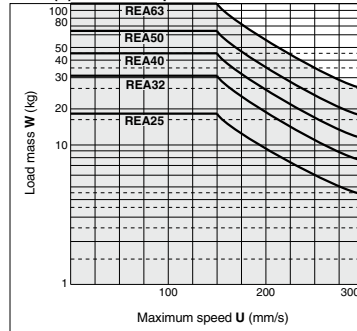

**REA**

**REB**

**REC**

**Smooth**

**Low Speed**

**MQ**

**RHC**

**RZQ**

**D-□**

**-X□**

## Caution on Design 2

### Cylinder Self-weight Deflection

When the cylinder is mounted horizontally, deflection appears due to its own weight as shown in the data, and the longer the stroke the greater the amount of variation in the shaft centers. A connection method as shown in the figure should be considered to allow for this deflection.

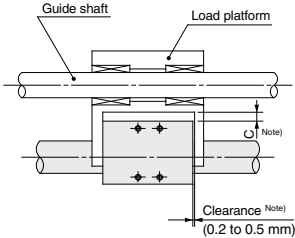

The above clearance is for reference.

Note) Referring to the self-weight deflection in the graph below, provide clearance so that the cylinder does not touch the mounting surface or the load section, and is able to operate smoothly within the minimum operating pressure range for a full stroke.

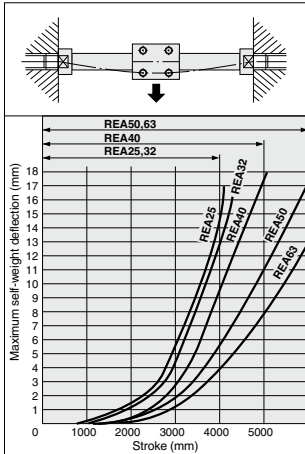

\* The above deflection data indicate values for external movement within the stroke.

### Max. Connection Fitting Mass

REA (Basic type) is not directly connected to the load, and is guided by another shaft (LM guide, etc.). Load connection fittings should be designed so that they do not exceed the mass given in the table below.

#### Maximum Connection Fitting Mass $W_{Bmax}$ (kg)

Model	Maximum load (kg)
REA25	1.2
REA32	1.5
REA40	2.0
REA50	2.5
REA63	3.0

\* When loading the mass exceeding the above values, please consult with SMC.

### Vertical Operation

The load should be guided by a ball type bearing (Linear guide, etc.). If a slide bearing is used, sliding resistance increases due to the load mass and load moment, which can cause malfunction. When the cylinder is mounted vertically or sidelong, sliders may move downwards due to the self-weight or workpiece mass. If an accurate stopping position is required at the stroke end or the middle-stroke, use an external stopper to secure accurate positioning.

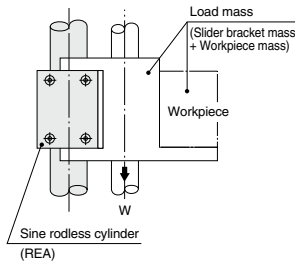

Model	Allowable load mass $W_w$ (kg)	Maximum operating pressure $P_v$ (MPa)
REA25	18.5	0.65
REA32	30.0	0.65
REA40	47.0	0.65
REA50	75.0	0.65
REA63	115.0	0.65

Note) Use caution, since the magnetic coupling may be dislocated if it is used over the maximum operating pressure.

### Intermediate Stop

The cushion effect (smooth start-up, soft stop) exists only before the stroke end in the stroke ranges indicated in the table below.

The cushion effect (smooth start-up, soft stop) cannot be obtained in an intermediate stop or a return from an intermediate stop using an external stopper, etc.

#### Cushion Stroke

Model	Stroke (mm)
REA25	30
REA32	30
REA40	35
REA50	40
REA63	40

# Sine Rodless Cylinder/Basic Type

# REA Series

ø25, ø32, ø40, ø50, ø63



## How to Order

### Basic type

REA 25 - 300 -

Sine rodless cylinder  
(Basic type)

Bore size

25	25 mm
32	32 mm
40	40 mm
50	50 mm
63	63 mm

Stroke (mm)

Refer to "Standard Stroke" below.

Port thread type

Symbol	Type	Bore size
NII	Rc	25, 32, 40
TN	NPT	50, 63
TF	G	32, 50, 63

Made to Order

Refer to the table below for details.

## Specifications

Bore size (mm)	25	32	40	50	63
Fluid	Air				
Proof pressure	1.05 MPa				
Maximum operating pressure	0.7 MPa				
Minimum operating pressure	0.18 MPa				
Ambient and fluid temperature	-10 to 60°C (No freezing)				
Piston speed (Max.) <sup>Note</sup>	50 to 300 mm/s				
Lubrication	Not required (Non-lube)				
Stroke length tolerance (mm)	0 to 250 st: $^{+1}_0$ , 251 to 100 st: $^{+1.4}_0$ , 1001 st or longer: $^{+1.8}_0$				
Holding force (N)	363	588	922	1,470	2,260

Note) Piston speed above indicates the maximum speed. It takes approximately 0.5 seconds (for one side) after the body moves from the stroke end until it goes through the cushion stroke, while it takes approximately 1 second for both sides.

## Standard Stroke

Bore size (mm)	Standard stroke (mm)	Maximum manufacturable stroke (mm)
25	200, 250, 300, 350, 400, 450, 500, 600, 700, 800	3000
32	200, 250, 300, 350, 400, 450, 500, 600, 700, 800	
40	200, 250, 300, 350, 400, 450, 500, 600, 700, 800, 900, 1000	
50	200, 250, 300, 350, 400, 450, 500, 600, 700, 800, 900, 1000	5000
63	200, 250, 300, 350, 400, 450, 500, 600, 700, 800, 900, 1000	

Note 1) Intermediate stroke is available in 1 mm increments.

Note 2) Strokes over 2000 mm are available as made-to-order. (Refer to -XB11.)

## Weight

Bore size (mm)	25	32	40	50	63
Basic weight	0.65	1.16	1.96	3.04	4.57
Additional weight per each 50 mm of stroke	0.023	0.033	0.04	0.077	0.096

Calculation: (Example) REA32-500 • Basic weight .....1.16 (kg)  
 • Additional weight .....0.033 (kg/50 st)  
 • Cylinder stroke .....500 (st) 1.16 + 0.033 x 500 ÷ 50 = 1.49 kg

### Symbol

Air cushion  
(Magnet type)

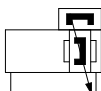

Made to Order: Individual Specifications  
(For details, refer to pages 111 and 112.)

Symbol	Specifications
-X168	Helical insert thread specifications
-X206	Additional moving element mounting taps
-X210	Non-lubricated exterior specifications
-X324	Non-lubricated exterior specifications with dust seal

### Made to Order Specifications

[Click here for details](#)

Symbol	Specifications
-XB11	Long stroke type
-XC24	With magnet shielding plate
-XC57	With floating joint

Refer to the "Pneumatic Clean Series" (CAT.E02-23) catalog for clean room specifications.

REA

REB

REC

Smooth

Low Speed

MQ

RHC

RZQ

# REA Series

## Construction

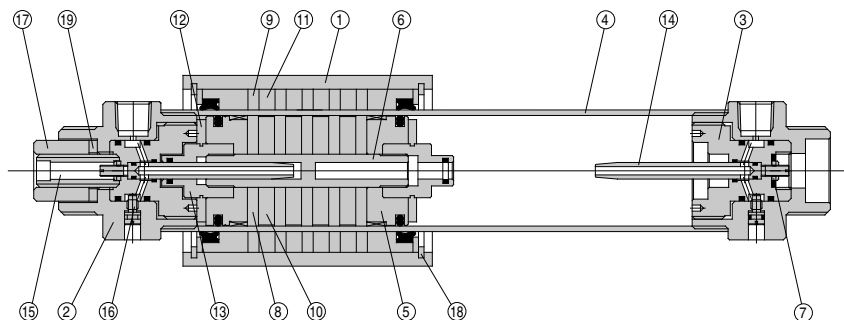

### Component Parts

No.	Description	Material	Note
1	Body	Aluminum alloy	Anodized
2	Head cover	Aluminum alloy	Anodized
3	Cushion ring holder	Aluminum alloy	Chromated
4	Cylinder tube	Stainless steel	
5	Piston	Aluminum alloy	Chromated
6	Shaft	Stainless steel	
7	Lock nut B	Carbon steel	Nickel plated
8	Piston side yoke	Rolled steel plate	Zinc chromated
9	External slider side yoke	Rolled steel plate	Zinc chromated
10	Magnet A	—	

### Component Parts

No.	Description	Material	Note
11	Magnet B	—	
12	Bumper	Urethane rubber	
13	Cushion seal holder	Aluminum alloy	Chromated
14	Cushion ring	Brass	Electroless nickel plated
15	Adjustment screw	Carbon steel	Nickel plated
16	Stopper bolt	Carbon steel	Nickel plated
17	Lock nut A	Carbon steel	Nickel plated
18	Retaining ring	Carbon tool steel	
19	Spring washer	Steel wire	

## Working principle

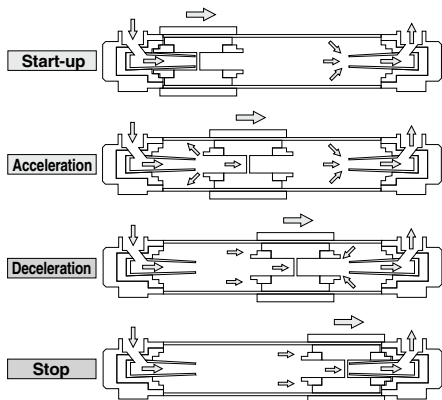

### Start-up/Acceleration

The driving air from the cylinder port passes through the inside of the cushion ring, and flows into the left chamber of the drive piston from the clearance between the cushion seal and the U-shaped groove in the outer surface of the cushion ring. Further, the exhaust air in the right chamber of the drive piston passes from inside the hollow cushion ring through the cylinder port and is released to the atmosphere by the drive solenoid valve.

When the differential pressure (thrust) generated on either side of the drive piston becomes larger than the starting resistance of the machinery, the drive piston begins to move to the right. As the drive piston moves to the right, the U-shaped groove in the outer surface of the cushion ring gradually becomes deeper, a flow corresponding to the drive speed of the drive piston flows into the left chamber of the drive piston, and the drive piston proceeds to accelerate. The U-shaped groove is machined into the cushion ring in such a way that this acceleration process can proceed smoothly (as a sine function).

### Deceleration/Stop

In current cushion mechanisms, when the cushion seal installed on the drive piston is pushed into the cushion ring at the right stroke end, the drive piston's right chamber is pressurized and a sudden braking force is generated.

However, in a sine rodless cylinder, due to the U-shaped groove provided on the outer surface of the cushion ring, whose depth changes as a sine function, a large quantity of the air in the cushion chamber is discharged when the cushion seal is pushed in, and a sudden braking force is not generated. With the progression of the cushion stroke, the discharge flow from the cushion chamber is restricted, and therefore, a soft stop is achieved at the stroke end.

**Dimensions**

**REA25/32/40**

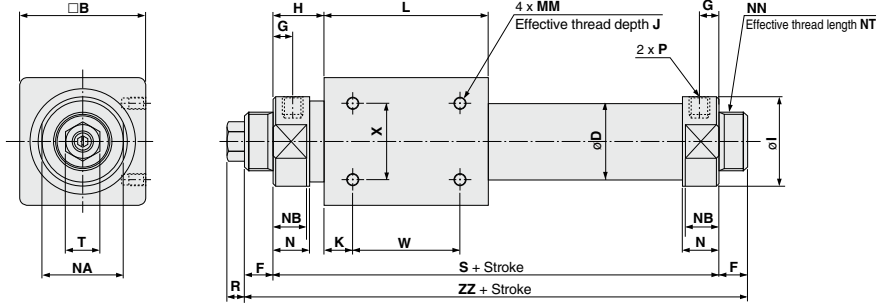

Model	Port size	B	D	F	G	H	I	K	L	MM x J	N	NT	NA	NB	NN
REA25	Rc 1/8	46	27.8	13	8	20.5	34	10	70	M5 x 0.8 x 8	15	11.5	30	13	M26 x 1.5
REA32	Rc 1/8	60	35	16	9	22	40	15	80	M6 x 1.0 x 8	17	13	36	15	M26 x 1.5
REA40	Rc 1/4	70	43	16	11	29	50	16	92	M6 x 1.0 x 10	21	13	46	19	M32 x 2.0

Model	P			S	W	X	ZZ	R	T
	Nil	TN	TF						
REA25	Rc 1/8	NPT 1/8	—	111	50	30	137	8	17
REA32	Rc 1/8	NPT 1/8	G1/8	124	50	40	156	8	17
REA40	Rc 1/4	NPT 1/4	—	150	60	40	182	10	19

**REA50/63**

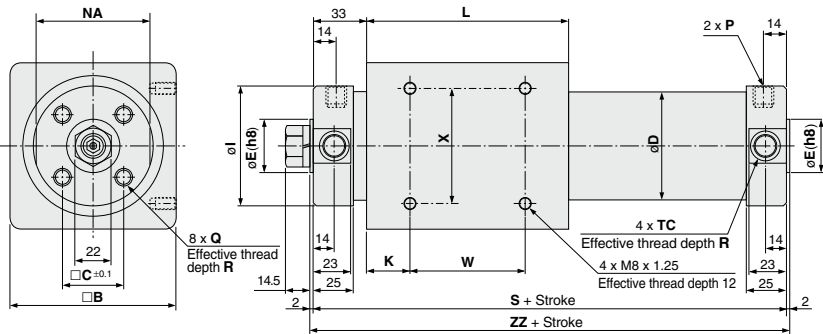

Model	B	C	D	E(h/8)	I	K	L	NA	P			Q x R	S	TC x R	W	X	ZZ
									Nil	TN	TF						
REA50	86	32	53	30 <sup>0.033</sup>	58.2	25	110	55	Rc 1/4	NPT 1/4	G 1/4	M8 x 1.25 x 16	176	M12 x 1.25 x 7.5	60	60	180
REA63	100	38	66	32 <sup>0.039</sup>	72.2	26	122	69	Rc 1/4	NPT 1/4	G 1/4	M10 x 1.5 x 16	188	M14 x 1.5 x 11.5	70	70	192

**Mounting Nuts: 2 pcs. Packaged with Each Cylinder**

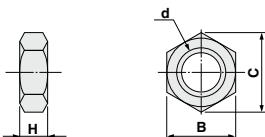

Model	Applicable bore size (mm)	d	H	B	C
SN-032B	ø25, ø32	M26 x 1.5	8	32	37
SN-040B	ø40	M32 x 2.0	11	41	47.3

- REA
- REB
- REC
- Smooth
- Low Speed
- MQ
- RHC
- RZQ

- D-
- X



# REA Series

## Specific Product Precautions

Be sure to read this before handling the products. Refer to back page 50 for Safety Instructions and pages 3 to 12 for Actuator and Auto Switch Precautions.

### Mounting

#### ⚠ Caution

- Take care to avoid nicks or other damage on the outside surface of the cylinder tube.**  
This can lead to a damage of the scraper and the wear ring, which in turn can cause malfunction.
- Use caution to the rotation of the external slider.**  
Rotation should be controlled by connecting it to another shaft (linear guide, etc.).
- Do not operate with the magnetic coupling out of position.**  
If the magnetic coupling is out of position, push the external slider by hand (or the piston slider with air pressure) back to the proper position at the stroke end.
- Be sure that both head covers are secured to the mounting surface before operating the cylinder.**  
Avoid operation with the external slider secured to the surface.
- Do not apply a lateral load to the external slider.**  
When a load is mounted directly to the cylinder, variations in the alignment of each shaft center cannot be offset, which results in the generation of a lateral load that can cause malfunction. The cylinder should be operated using a connection method which allows for shaft alignment variations and deflection due to the cylinder's own mass. A drawing of a recommended mounting is shown in Fig. (2).

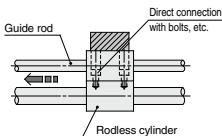

Variations in the load and cylinder shaft alignment cannot be offset and may result in a malfunction.

Fig. (1) Incorrect mounting

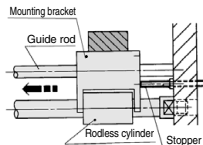

Shaft alignment variations are offset by providing clearance between the mounting bracket and cylinder. Moreover, the mounting bracket is extended above the cylinder shaft center, so that the cylinder is not subjected to moment.

Fig. (2) Recommended mounting

#### 6. Use caution regarding the allowable load mass when operating in a vertical direction.

The allowable load mass when operating in a vertical direction (reference values on page 24 is determined by the model selection method). However, if a load greater than the allowable value is applied, the magnetic coupling may break and there is a possibility of dropping the load. When using this type of application, please contact SMC regarding the operating conditions (pressure, load, speed).

### Disassembly and Maintenance

#### ⚠ Caution

- When reattaching the head covers after disassembly, confirm that they are tightened securely.**  
When disassembling, hold the wrench flats of one head cover with a vise, and remove the other cover using a spanner or adjustable wrench on the wrench flats. When retightening, first coat with Loctite® (no. 542 Red), and retighten 3° to 5° past the original position prior to removal.

### Stroke Adjustment

#### ⚠ Caution

- This mechanism is not intended for adjustment of the cushion effect (smooth start-up, soft stop). This mechanism is for matching of the cylinder's stroke end position to the mechanical stopper, etc., of a machine. (adjustment range from 0 to -2 mm)
- Before adjustment is performed, shut off the drive air, release any residual pressure and implement measures to prevent dropping of workpieces, etc.

### Stroke End Adjustment

(To ensure safety, implement with air shut down.)

#### ⚠ Caution

- Loosen lock nut A.
- Insert a wrench into the hexagon socket of the adjusting screw, and turn it to the left or right, matching the cushion ring holder (stroke end) with the position of the external stopper by moving it backward or forward.
- After the stroke end adjustment is completed, retighten lock nut A, and apply high strength Loctite® no. 262 or another comparable locking agent.

#### Adjusting Screw Hexagon Socket

Model	Width across flats (mm)
REA25	5
REA32	5
REA40	6
REA50	8
REA63	8

#### Lock Nut A tightening Torque

Model	Tightening torque (N·m)
REA25	1.2
REA32	1.2
REA40	2.1
REA50	3.4
REA63	3.4

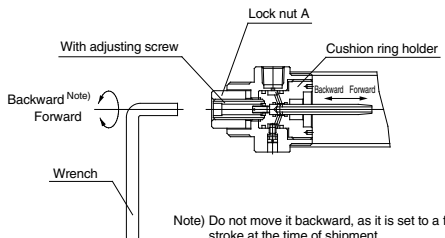

# Direct Mount Type

## *REAR Series*

ø10, ø15, ø20, ø25, ø32, ø40



**REA**

**REB**

**REC**

Smooth

Low  
Speed

**MQ**

**RHC**

**RZQ**

**D-□**

**-X□**

# REAR Series Model Selection

**F<sub>n</sub>**: Allowable driving force (N)  
**M<sub>b</sub>**: Maximum allowable moment when connection fitting, etc., is directly loaded (N·m)  
**P<sub>v</sub>**: Maximum operating pressure for vertical operation (MPa)  
**W<sub>amax</sub>**: Maximum load mass when loaded directly on the body (kg)  
**W<sub>v</sub>**: Allowable load mass for vertical operation (kg)

**Operating Conditions**

- **W**: Load mass (kg)
- **W<sub>b</sub>**: Connection fitting mass (kg)
- **μ**: Guide's coefficient of friction
- **L<sub>o</sub>**: Distance from cylinder shaft center to workpiece point of application (cm)
- **L<sub>1</sub>**: Distance from the cylinder shaft center to the center of the gravity of connection fitting, etc. (mm)
- **Presence of switches**
- **P**: Operating pressure (MPa)
- **U**: Maximum speed (mm/s)
- **Stroke (mm)**
- **Mode of operation** (horizontal, inclined, vertical)

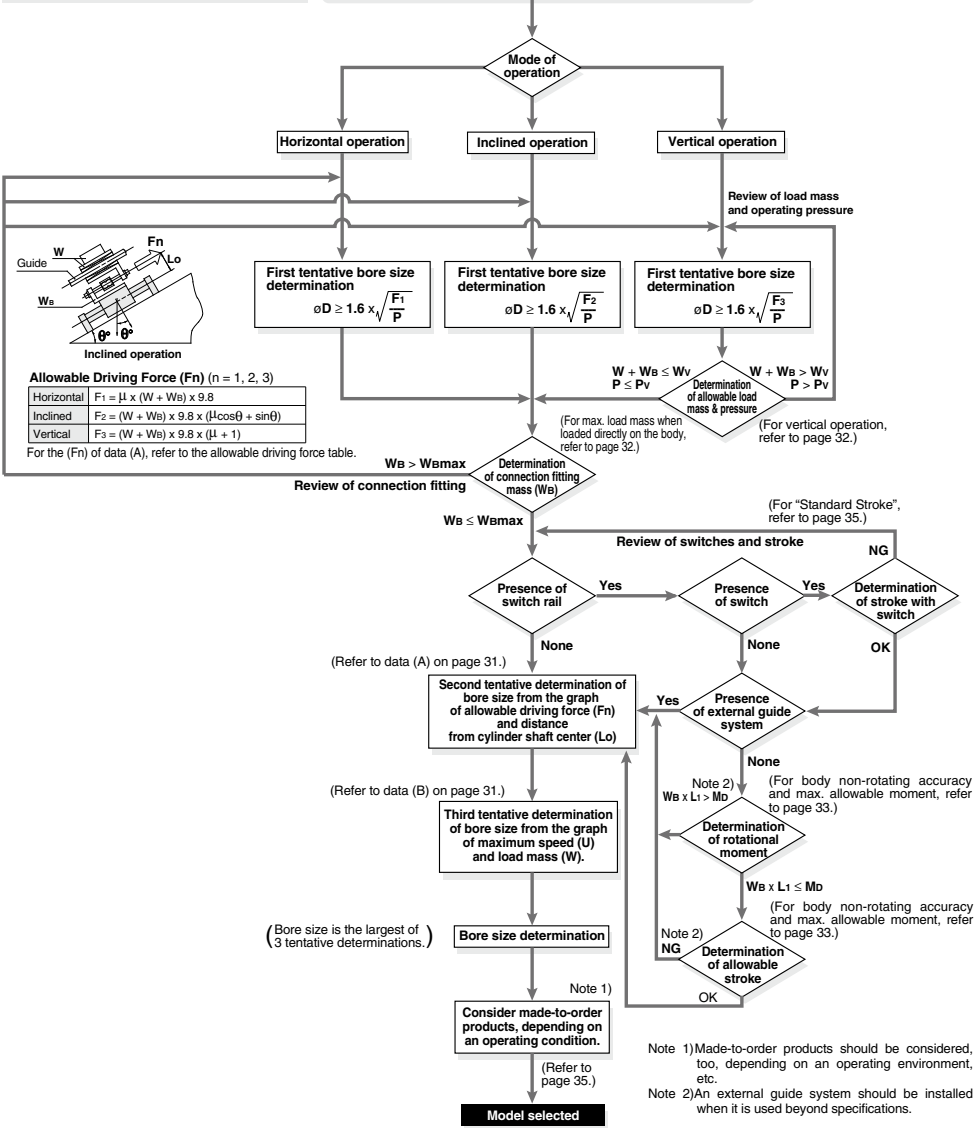



**Caution on Design 1**

**Selection Method**

**Selection Procedures**

1. Find the drive resisting force  $F_n$  (N) when moving the load horizontally.
2. Find the distance  $L_o$  (cm) from the point of the load where driving force is applied, to the center of the cylinder shaft.
3. Select a bore size from  $L_o$  and  $F_n$  in Data (A).

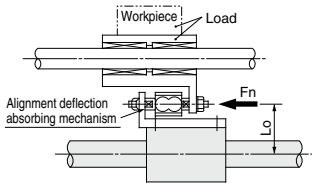

**<Data (A): Distance from Cylinder Shaft Center — Allowable Driving Force>**

**φ10**

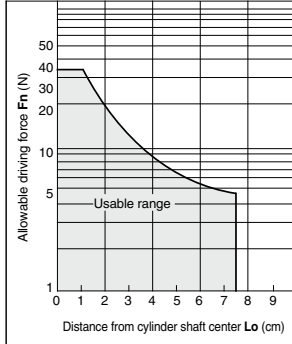

**φ15**

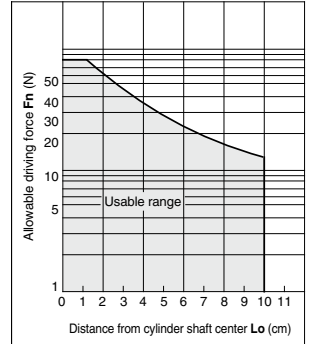

**RE A**

**RE B**

**RE C**

**Smooth**

**Low Speed**

**MQ**

**RHC**

**RZQ**

**Selection Example**

Given a load drive resisting force of  $F_n = 100$  (N) and a distance from the cylinder shaft center to the load application point of  $L_o = 8$  cm, find the intersection point by extending upward from the horizontal axis of data (A) where the distance from the shaft center is 8 cm, and then extending to the side, find the allowable driving force on the vertical axis. Models suitable to satisfy the requirement of 100 (N) are **REAR32** or **REAR40**.

\* Distance from cylinder shaft center,  $L_o$  is the moment working point between the cylinder and the load.

**φ20**

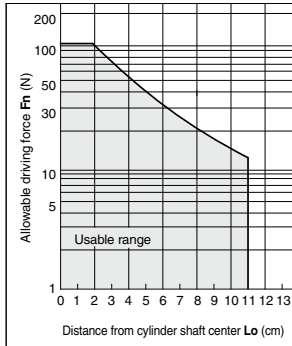

**φ25**

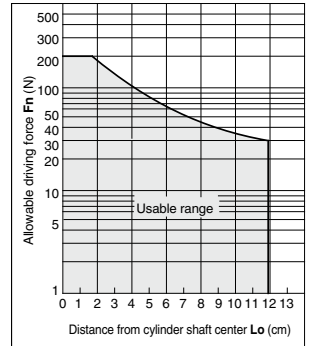

**<Data (B): Maximum Speed — Load Mass Chart>**

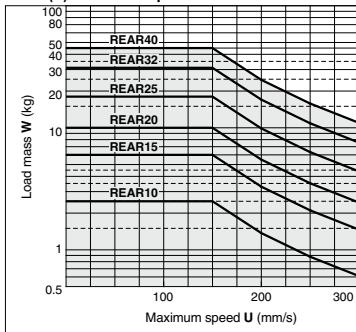

**φ32**

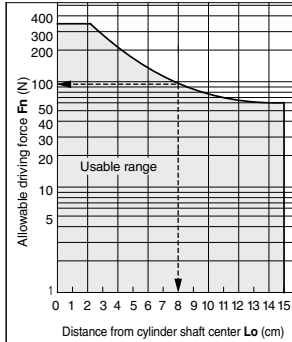

**φ40**

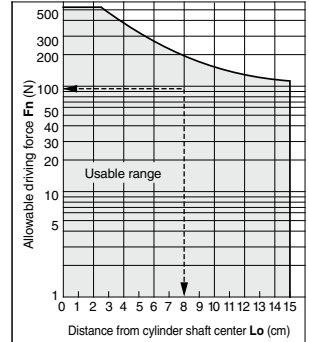

**D-□**

**-X□**

# REAR Series

## Caution on Design 2

### Cylinder Self-weight Deflection

When the cylinder is mounted horizontally, deflection appears due to its own weight as shown in the data, and the longer the stroke, the greater the amount of variation in the shaft centers. Therefore, a connection method should be considered which allows for this variation as shown in the drawing.

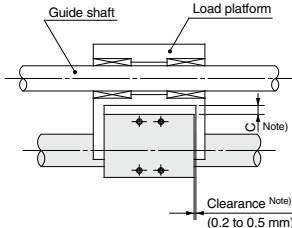

The above clearance is for reference.

Note) Referring to the self-weight deflection in the graph below, provide clearance so that the cylinder does not touch the mounting surface or the load section, and is able to operate smoothly within the minimum operating pressure range for a full stroke.

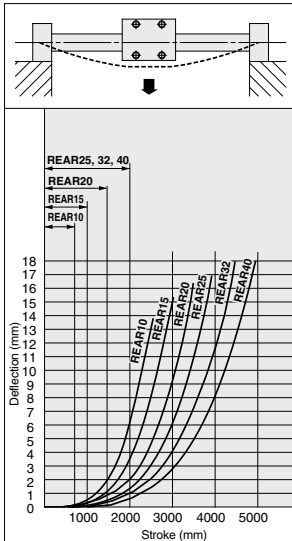

\* The above deflection data indicate values when the external slider has moved to the middle of the stroke.

### Vertical Operation

The load should be guided by a ball type bearing (Linear guide, etc.). If a slide bearing is used, sliding resistance will increase due to the load weight and moment, and this can cause malfunction.

When the cylinder is mounted vertically or sidelong, sliders may move downwards due to the self-weight or workpiece mass. If an accurate stopping position is required at the stroke end or the middle-stroke, use an external stopper to secure accurate positioning.

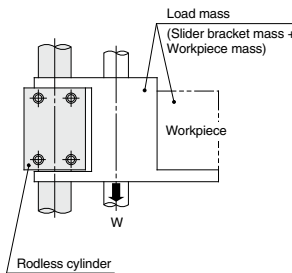

### Maximum Load Mass when Loaded Directly on Body

When the load is applied directly to the body, it should be no greater than the maximum values shown in the table below.

Model	Maximum load mass $W_{max}$ (kg)
<b>REAR 10</b>	0.4
<b>REAR 15</b>	1.0
<b>REAR 20</b>	1.1
<b>REAR 25</b>	1.2
<b>REAR 32</b>	1.5
<b>REAR 40</b>	2.0

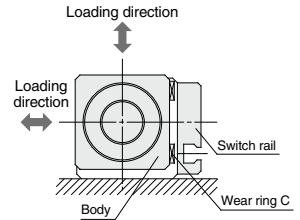

Bore size (mm)	Model	Allowable load mass $W_v$ (kg)	Maximum operating pressure $P_v$ (MPa)
10	<b>REAR10</b>	2.7	0.55
15	<b>REAR15</b>	7.0	0.65
20	<b>REAR20</b>	11.0	0.65
25	<b>REAR25</b>	18.5	0.65
32	<b>REAR32</b>	30.0	0.65
40	<b>REAR40</b>	47.0	0.65

Note) Use caution, since the magnetic coupling may be dislocated if it is used over the maximum operating pressure.

**Caution on Design 3**

**Intermediate Stop**

The cushion effect (smooth start-up, soft stop) exists only before the stroke end in the stroke ranges indicated in the table below.

The cushion effect (smooth start-up, soft stop) cannot be obtained in an intermediate stop or return from an intermediate stop using an external stopper, etc.

**Cushion Stroke**

Model	Stroke (mm)
<b>REAR10</b>	20
<b>REAR15</b>	25
<b>REAR20</b>	30
<b>REAR25</b>	30
<b>REAR32</b>	30
<b>REAR40</b>	35

**Body Non-rotating Accuracy and Max. Allowable Moment (With switch rail) (Reference values)**

Reference values for non-rotating accuracy and maximum allowable moment at stroke end are indicated below.

Bore size (mm)	Non-rotating accuracy (°)	Maximum allowable moment $M_b$ (N·m)	Allowable <sup>(2)</sup> stroke (mm)
<b>10</b>	6.0	0.05	100
<b>15</b>	4.5	0.15	200
<b>20</b>	3.7	0.20	300
<b>25</b>	3.7	0.25	300
<b>32</b>	3.1	0.40	400
<b>40</b>	2.8	0.62	400

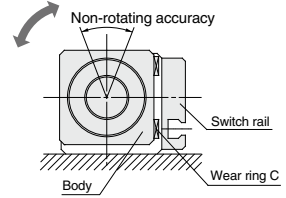

Note 1) Avoid operations where rotational torque (moment) is applied. In such a case, the use of an external guide is recommended.

Note 2) The above reference values will be satisfied within the allowable stroke ranges. However, caution is necessary because as the stroke becomes longer the inclination (rotation angle) within the stroke can be expected to increase.

Note 3) When a load is applied directly to the body, the work load should be no greater than the allowable load mass on page 32.

**REA**

**REB**

**REC**

**Smooth**

**Low Speed**

**MQ**

**RHC**

**RZQ**

**D-□**

**-X□**

# Sine Rodless Cylinder/Direct Mount Type

# REAR Series

ø10, ø15, ø20, ø25, ø32, ø40

## How to Order

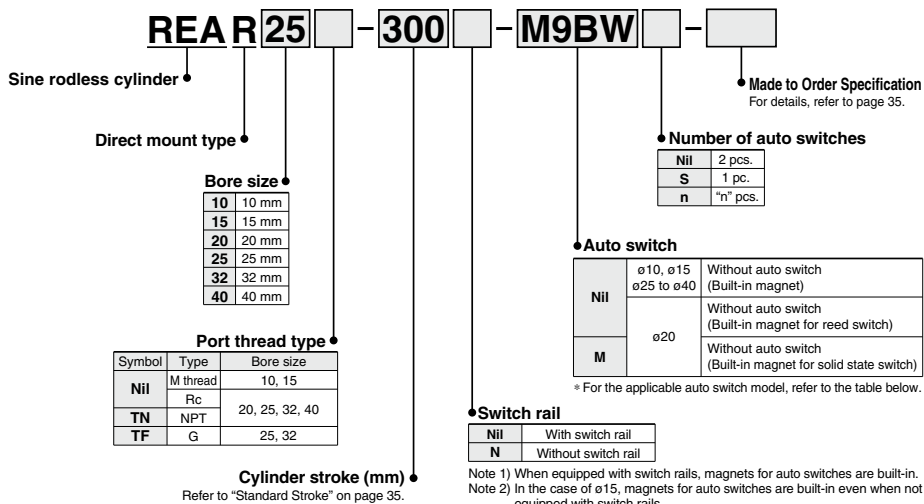

Note 1) When equipped with switch rails, magnets for auto switches are built-in.  
Note 2) In the case of ø15, magnets for auto switches are built-in even when not equipped with switch rails.

## Applicable Auto Switches/Refer to pages 941 to 1067 for further information on auto switches.

Type	Special function	Electrical entry	Indicator light	Wiring (Output)	Load voltage		Auto switch model	Lead wire length (m)				Pre-wired connector	Applicable load	
					DC	AC		0.5 (Nil)	1 (M)	3 (L)	5 (Z)			
Solid state auto switch	—	Grommet	Yes	3-wire (NPN)	24 V	5 V, 12 V	M9N	●	●	○	○	IC circuit	Relay, PLC	
				3-wire (PNP)			M9P	●	●	○	○			
				2-wire			M9B	●	●	○	○			
	Diagnostic indication (2-color indicator)			3-wire (NPN)	5 V, 12 V	M9NW	●	●	○	○	IC circuit			
				3-wire (PNP)		M9PW	●	●	○	○				
				2-wire		M9BW	●	●	○	○				
	Water resistant (2-color indicator)			3-wire (NPN)	5 V, 12 V	M9NA*1	○	○	●	○	IC circuit			
				3-wire (PNP)		M9PA*1	○	○	●	○				
				2-wire		M9BA*1	○	○	●	○				
Reed auto switch	—	Grommet	Yes	3-wire (NPN equivalent)	24 V	12 V	A96	●	—	●	—	IC circuit	—	
				2-wire			A93	●	●	●	●	—		Relay, PLC
							A90	●	—	●	—	—		IC circuit

\*1 Water resistant type auto switches can be mounted on the above models, but in such case SMC cannot guarantee water resistance. Consult with SMC regarding water resistant types with the above model numbers.

- \* Lead wire length symbols: 0.5 m.....Nil (Example) M9NW  
1 m.....M (Example) M9NWM  
3 m.....L (Example) M9NWL  
5 m.....Z (Example) M9NWX
- \* Solid state auto switches marked with "○" are produced upon receipt of order.
- \* Since there are other applicable auto switches than listed, refer to page 39 for details.
- \* For details about auto switches with pre-wired connector, refer to pages 1014 and 1015.
- \* Auto switches are shipped together (not assembled).



**Symbol**

Air cushion  
(Magnet type)



**Made to Order Specifications**

[Click here for details](#)

Symbol	Specifications
-XC57	With floating joint

**Specifications**

Bore size (mm)	10	15	20	25	32	40
<b>Fluid</b>	Air					
<b>Proof pressure</b>	1.05 MPa					
<b>Maximum operating pressure</b>	0.7 MPa					
<b>Minimum operating pressure</b>	0.18 MPa					
<b>Ambient and fluid temperature</b>	-10 to 60°C (No freezing)					
<b>Piston speed (Max.)</b> <sup>Note</sup>	50 to 300 mm/s					
<b>Lubrication</b>	Not required (Non-lube)					
<b>Stroke length tolerance (mm)</b>	0 to 250 st: $^{+1.0}_0$ , 251 to 1000 st: $^{+1.4}_0$ , 1001 st or longer: $^{+1.8}_0$					
<b>Holding force (N)</b>	53.9	137	231	363	588	922

Note) Piston speed above indicates the maximum speed. It takes approximately 0.5 seconds (for one side) after the body moves from the stroke end until it goes through the cushion stroke, while it takes approximately 1 second for both sides.

**Standard Stroke**

Bore size (mm)	Standard stroke (mm)	Maximum manufacturable stroke (mm)	Maximum stroke with switch stroke (mm)
<b>10</b>	150, 200, 250, 300	500	500
<b>15</b>	150, 200, 250, 300, 350, 400, 450, 500	1000	750
<b>20</b>	200, 250, 300, 350, 400, 450, 500, 600, 700, 800	1500	1000
<b>25</b>		2000	1500
<b>32</b>			
<b>40</b>	200, 250, 300, 350, 400, 450, 500, 600, 700, 800, 900, 1000	2000	1500

Note) Intermediate stroke is available in 1 mm increments.

**Weight**

Item	Bore size (mm)	(kg)					
		10	15	20	25	32	40
Basic weight (for 0 st)	REAR□ (with switch rail)	0.111	0.277	0.440	0.660	1.27	2.06
	REAR□-□N (without switch rail)	0.080	0.230	0.370	0.580	1.15	1.90
Additional weight per each 50 mm of stroke (when equipped with switch rail)		0.034	0.045	0.071	0.083	0.113	0.133
Additional weight per each 50 mm of stroke (when not equipped with switch rail)		0.014	0.020	0.040	0.050	0.070	0.080

Calculation: (Example) **REAR25-500** (with switch rail) • Basic weight ..... 0.660 (kg)  
 • Additional weight ..... 0.083 (kg/50 st)  
 • Cylinder stroke ..... 500 (st)  
 0.660 + 0.083 x 500 + 50 = 1.49 kg

REA

REB

REC

Smooth

Low Speed

MQ

RHC

RZQ

D-□

-X□

# REAR Series

Construction:  $\phi 10, \phi 15$

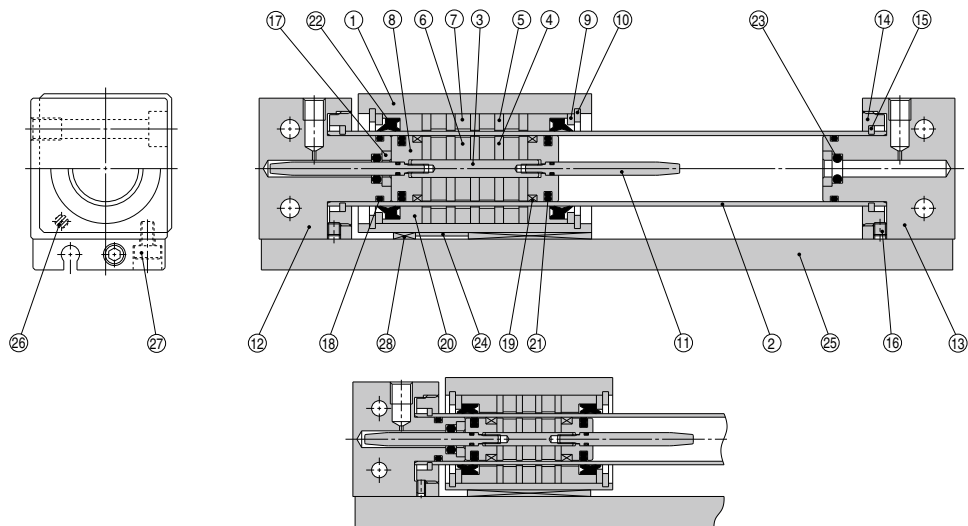

REAR10

## Component Parts

No.	Description	Material	Note
1	Body	Aluminum alloy	Hard anodized
2	Cylinder tube	Stainless steel	
3	Shaft	Stainless steel	Zinc chromated
4	Piston side yoke	Rolled steel plate	Zinc chromated
5	External slider side yoke	Rolled steel plate	
6	Magnet A	—	
7	Magnet B	—	
8	Piston	Aluminum alloy	Chromated
9	Spacer	Rolled steel plate	Nickel plated
10	Retaining ring	Carbon tool steel	Phosphate coated
11	Cushion ring	Stainless steel	
12	End cover A	Aluminum alloy	Hard anodized
13	End cover B	Aluminum alloy	Hard anodized
14	Attachment ring	Aluminum alloy	Hard anodized
15	Type C retaining ring for axis	Stainless steel	REAR10
		Hard steel wire material	Nickel plated (REAR15)
16	Hexagon socket head set screw	Chromium steel	Nickel plated
17	Retaining plate	Aluminum alloy	

## Component Parts

No.	Description	Material	Note
18 <sup>*</sup>	Cylinder tube gasket	NBR	
19 <sup>*</sup>	Wear ring A	Special resin	
20 <sup>*</sup>	Wear ring B	Special resin	
21 <sup>*</sup>	Piston seal	NBR	
22 <sup>*</sup>	Scraper	NBR	
23 <sup>*</sup>	Cushion seal	NBR	
24	Magnetic shielding plate	Rolled steel plate	Chromated
25	Switch rail	Aluminum alloy	Clear anodized
26	Magnet	—	
27	Hexagon socket head cap screw	Chromium steel	Nickel plated
28 <sup>*</sup>	Wear ring C	Special resin	

## Replacement Parts: Seal Kit

Bore size (mm)	Kit no.	Contents
10	REAR10-PS	Set of nos. above (18, 19, 20, 21, 22, 23) (Note 1) (Note 2)
15	REAR15-PS	Set of nos. above (18, 19, 20, 21, 22, 23) (Note 1)

Note 1) It may be difficult to replace the cushion seal (23).  
 Note 2) For replacement of wear ring A (19) of  $\phi 10$ , please consult with SMC.  
 \* Seal kit includes a grease pack ( $\phi 10$ : 5 g and 10 g,  $\phi 15$ : 10 g).  
 Order with the following part number when only the grease pack is needed.  
**For  $\phi 10$  grease pack part no.: GR-F-005 (5 g) For external sliding part GR-S-010 (10 g) For tube interior**  
**For  $\phi 15$  grease pack part no.: GR-S-010 (10 g)**

## Switch Rail Accessory Kit

**CYR 20EB(N) - 200**

Stroke

Bore size

Auto switch type ( $\phi 20$  only)

Nil	For reed switch
N	For solid state switch

## Switch Rail Accessory Kit

Bore size (mm)	Kit no.	Contents
10	CYR10EB-□	Above nos. 25, 26, 27, 28
15	CYR15EB-□	Above nos. 24, 25, 27, 28 (Note 2)

Note 1) □ indicates the stroke.  
 Note 2)  $\phi 15$  has internal magnets in the body.

**Construction:  $\phi 20$  to  $\phi 40$**

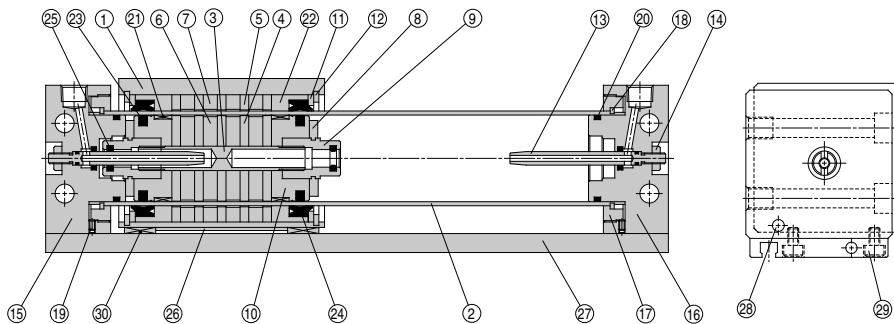

**Component Parts**

No.	Description	Material	Note
1	Body	Aluminum alloy	Hard anodized
2	Cylinder tube	Stainless steel	
3	Shaft	Stainless steel	
4	Piston side yoke	Rolled steel plate	Zinc chromated
5	External slider side yoke	Rolled steel plate	Zinc chromated
6	Magnet A	—	
7	Magnet B	—	
8	Bumper	Urethane rubber	
9	Cushion seal holder	Aluminum alloy	Chromated
10	Piston	Aluminum alloy	Chromated
11	Spacer	Rolled steel plate	Nickel plated
12	Retaining ring	Carbon tool steel	Phosphate coated
13	Cushion ring	Brass	Electroless nickel plated (REAR 32, 40)
		Stainless steel	REAR 20, 25
14	Lock nut B	Carbon steel	Nickel plated
15	End cover A	Aluminum alloy	Hard anodized
16	End cover B	Aluminum alloy	Hard anodized
17	Attachment ring	Aluminum alloy	Hard anodized
18	Type C retaining ring for axis	Stainless steel	REAR 25, 32
		Hard steel wire material	Nickel plated (REAR 20, 40)
19	Hexagon socket head set screw	Chromium steel	Nickel plated

**Component Parts**

No.	Description	Material	Note
20*	Cylinder tube gasket	NBR	
21*	Wear ring A	Special resin	
22*	Wear ring B	Special resin	
23*	Piston seal	NBR	
24*	Scraper	NBR	
25*	Cushion seal	NBR	Chromated
26	Magnetic shielding plate	Rolled steel plate	Clear anodized
27	Switch rail	Aluminum alloy	
28	Magnet	—	Nickel plated
29	Hexagon socket head cap screw	Chromium steel	
30*	Wear ring C	Special resin	

\* Seal kit includes 20 to 25, 28. Order the seal kit, based on each bore size.

**Replacement Parts: Seal Kit**

Bore size (mm)	Kit no.	Contents
20	REAR20-PS	Above nos. 20, 21, 22, 23, 24, 25, 28 (Note)
25	REAR25-PS	
32	REAR32-PS	
40	REAR40-PS	

Note) Cushion seal (25) may be difficult to be replaced.

\* Seal kit includes a grease pack (10 g).

Order with the following part number when only the grease pack is needed.

Grease pack part no.: GR-S-010 (10 g)

**Switch Rail Accessory Kit**

**CYR 20 EB(N) - 200**

Bore size

Stroke

Auto switch type  
( $\phi 20$  only)

Nil	For reed switch
N	For solid state switch

**Switch Rail Accessory Kit**

Bore size (mm)	Kit no.	Contents
20	For reed switch	CYR20EB-□
	For solid state switch	CYR20EBN-□
25		CYR25EB-□
32		CYR32EB-□
40		CYR40EB-□

Note) □ indicates the stroke.

REA

REB

REC

Smooth

Low Speed

MQ

RHC

RZQ

D-□

-X□

# REAR Series

## Dimensions

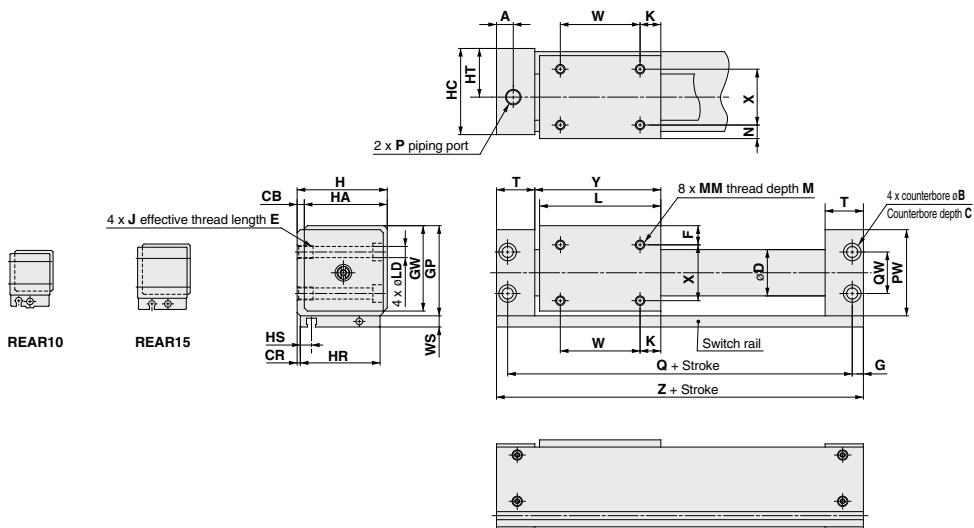

(mm)

Model	A	B	C	CB	CR	D	F	G	GP	GW	H	HA	HC	HR	HS	HT	J x E
REAR10	10.5	6.5	3.2	2	0.5	12	6.5	6	27	25.5	26	24	25	24	5	14	M4 x 0.7 x 6
REAR15	12	8	4.2	2	0.5	17	8	7	33	31.5	32	30	31	30	8.5	17	M5 x 0.8 x 7
REAR20	9	9.5	5.2	3	1	22.8	9	6	39	37.5	39	36	38	36	7.5	21	M6 x 1 x 8
REAR25	8.5	9.5	5.2	3	1	27.8	8.5	6	44	42.5	44	41	43	41	6.5	23.5	M6 x 1 x 8
REAR32	10.5	11	6.5	3	1.5	35	10.5	7	55	53.5	55	52	54	51	7	29	M8 x 1.25 x 10
REAR40	10	11	6.5	5	2	43	13	7	65	63.5	67	62	66	62	8	36	M8 x 1.25 x 10

Model	K	L	LD	M	MM	N	P			PW	Q	QW	T	W	WS	X	Y	Z
							Nil	TN	TF									
REAR10	9	38	3.5	4	M3 x 0.5	4.5	M5 x 0.8	—	—	26	68	14	19.5	20	8	15	39.5	80
REAR15	14	53	4.3	5	M4 x 0.7	6	M5 x 0.8	—	—	32	84	18	21	25	7	18	54.5	98
REAR20	11	62	5.6	5	M4 x 0.7	7	Rc 1/8	NPT 1/8	—	38	95	17	20.5	40	7	22	64	107
REAR25	15	70	5.6	6	M5 x 0.8	6.5	Rc 1/8	NPT 1/8	G 1/8	43	105	20	21.5	40	7	28	72	117
REAR32	13	76	7	7	M6 x 1	8.5	Rc 1/8	NPT 1/8	G 1/8	54	116	26	24	50	7	35	79	130
REAR40	15	90	7	8	M6 x 1	11	Rc 1/4	NPT 1/4	—	64	134	34	26	60	7	40	93	148



# REAR Series Auto Switch Mounting

## Auto Switch Proper Mounting Position (Detection at Stroke End)

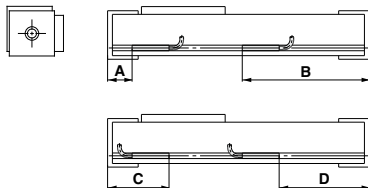

### Auto Switch Proper Mounting Position

ø10 to ø40

Auto switch model Bore size (mm)	A		B		C		D	
	D-A9□	D-M9□ D-M9□W D-M9□A	D-A9□	D-M9□ D-M9□W D-M9□A	D-A9□	D-M9□ D-M9□W D-M9□A	D-A9□	D-M9□ D-M9□W D-M9□A
10	30	34	50	46	50	46	—	34
15	19.5	23.5	78.5	74.5	—	—	58.5	62.5
20	19.5	23.5	87.5	83.5	39.5	35.5	67.5	71.5
25	19	23	98	94	42	38	75	79
32	22.5	26.5	107.5	103.5	45.5	41.5	84.5	88.5
40	24.5	28.5	123.5	119.5	47.5	43.5	100.5	104.5

Note 1) Auto switches cannot be installed in Area C in the case of ø15.

Note 2) D-A9□ cannot be mounted on D of ø10.

Note 3) Adjust the auto switch after confirming the operating conditions in the actual setting.

ø25 to ø40

Auto switch model Bore size (mm)	A	B	C	D
	D-Z7□ D-Z80 D-Y59□ D-Y7P D-Y7□W	18	D-Z7□ D-Z80 D-Y59□ D-Y7P D-Y7□W	99
25	18	99	43	74
32	21.5	108.5	46.5	83.5
40	23.5	124.5	48.5	99.5

Note) Adjust the auto switch after confirming the operating conditions in the actual setting.

### Operating Range

Auto switch model	Bore size (mm)					
	10	15	20	25	32	40
D-A9□	13	8	6	7.5	8	9
D-M9□W						
D-M9□	6.5	4.5	5.5	4	4.5	5
D-M9□A						
D-Z7□/Z80	—	—	—	9	9	11
D-Y5□/Y7P/Y7□W	—	—	—	7	6	6

\* Since this is a guideline including hysteresis, not meant to be guaranteed. (assuming approximately ±30% dispersion)  
There may be the case it will vary substantially depending on an ambient environment.

### Auto Switch Mounting Bracket: Part No.

Auto switch model	Bore size (mm)
	D-A9□ D-M9□ D-M9□W D-M9□A
	BMG2-012

D-A9□/M9□/M9□W/M9□A

BMG2-012

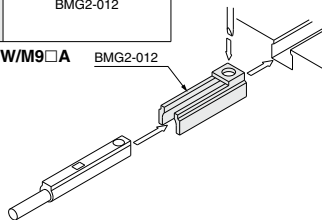

Other than the models listed in "How to Order", the following auto switches are applicable. For detailed specifications, refer to pages 941 to 1067.

Auto switch type	Model	Electrical entry (Fetching direction)	Features	Applicable bore size
Reed	D-Z73, Z76	Grommet (In-line)	—	ø25 to ø40
	D-Z80		Without indicator light	
Solid state	D-Y59A, Y59B, Y7P	Grommet (In-line)	—	
	D-Y7NW, Y7PW, Y7BW		Diagnostic indication (2-color indicator)	

\* For solid state auto switches, auto switches with a pre-wired connector are also available. Refer to pages 1014 and 1015 for details.

\* Normally closed (NC = b contact) solid state auto switches (D-F9G/F9H/Y7G/Y7H types) are also available. Refer to pages 959 and 961 for details.

REA

REB

REC

Smooth

Low Speed

MQ

RHC

RZQ

D-□

-X□



## REAR Series

# Specific Product Precautions

Be sure to read this before handling the products. Refer to back page 50 for Safety Instructions and pages 3 to 12 for Actuator and Auto Switch Precautions.

### Mounting

#### ⚠ Caution

1. Take care to avoid nicks or other damage on the outside surface of the cylinder tube.

This can lead to a damage of the scraper and the wear ring, which in turn can cause malfunction.

2. Use caution to the rotation of the external slider.

Rotation should be controlled by connecting it to another shaft (linear guide, etc.).

3. Do not operate with the magnetic coupling out of position.

If the magnetic coupling is out of position, push the external slider by hand (or the piston slider with air pressure) back to the proper position at the stroke end.

4. The cylinder is mounted with bolts through the mounting holes in the end covers. Be sure they are tightened securely.

5. Be sure that both end covers are secured to the mounting surface before operating the cylinder.

Avoid operation with the external slider secured to the surface.

6. Do not apply a lateral load to the external slider.

When a load is mounted directly to the cylinder, variations in the alignment of each shaft center cannot be offset, which results in the generation of a lateral load that can cause malfunction. The cylinder should be operated using a connection method which allows for shaft alignment variations and deflection due to the cylinder's own weight. A drawing of a recommended mounting is shown in Fig. (2).

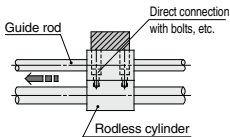

Variations in the load and cylinder shaft alignment cannot be offset and may result in a malfunction.

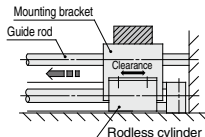

Shaft alignment variations are offset by providing clearance between the mounting bracket and cylinder. Moreover, the mounting bracket is extended above the cylinder shaft center, so that the cylinder is not subjected to moment.

Figure (1) Incorrect mounting

Figure (2) Recommended mounting

7. Use caution regarding the allowable load mass when operating in a vertical direction.

The allowable load mass when operating in a vertical direction (reference values on page 32) is determined by the model selection method, however, if a load greater than the allowable value is applied, the magnetic coupling may break and there is a possibility of dropping the load. When using this type of application, please contact SMC regarding the operating conditions (pressure, load).

### Disassembly and Maintenance

#### ⚠ Caution

1. Special tools are necessary for disassembly.

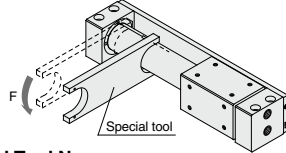

#### Special Tool No.

Part no.	Applicable bore size (mm)
CYRZ-V	10, 15, 20
CYRZ-W	25, 32, 40

# Slider Type/Slide Bearing

## *REAS Series*

ø10, ø15, ø20, ø25, ø32, ø40

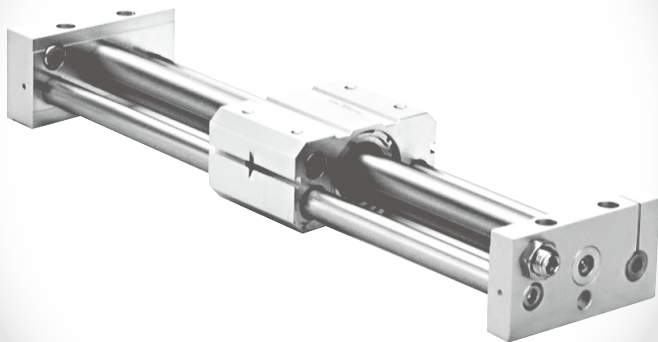

REA

REB

REC

Smooth

Low  
Speed

MQ

RHC

RZQ

D-□

-X□

# REAS Series Model Selection

Pv: Maximum operating pressure for vertical operation (MPa)  
 Wa: Allowable load mass based on these operating conditions (kg)  
 Wv: Allowable load mass for vertical operation (kg)  
 σ: Stroke coefficient

$$\sigma = \frac{\text{Load mass in stroke}}{\text{Maximum load mass}}$$

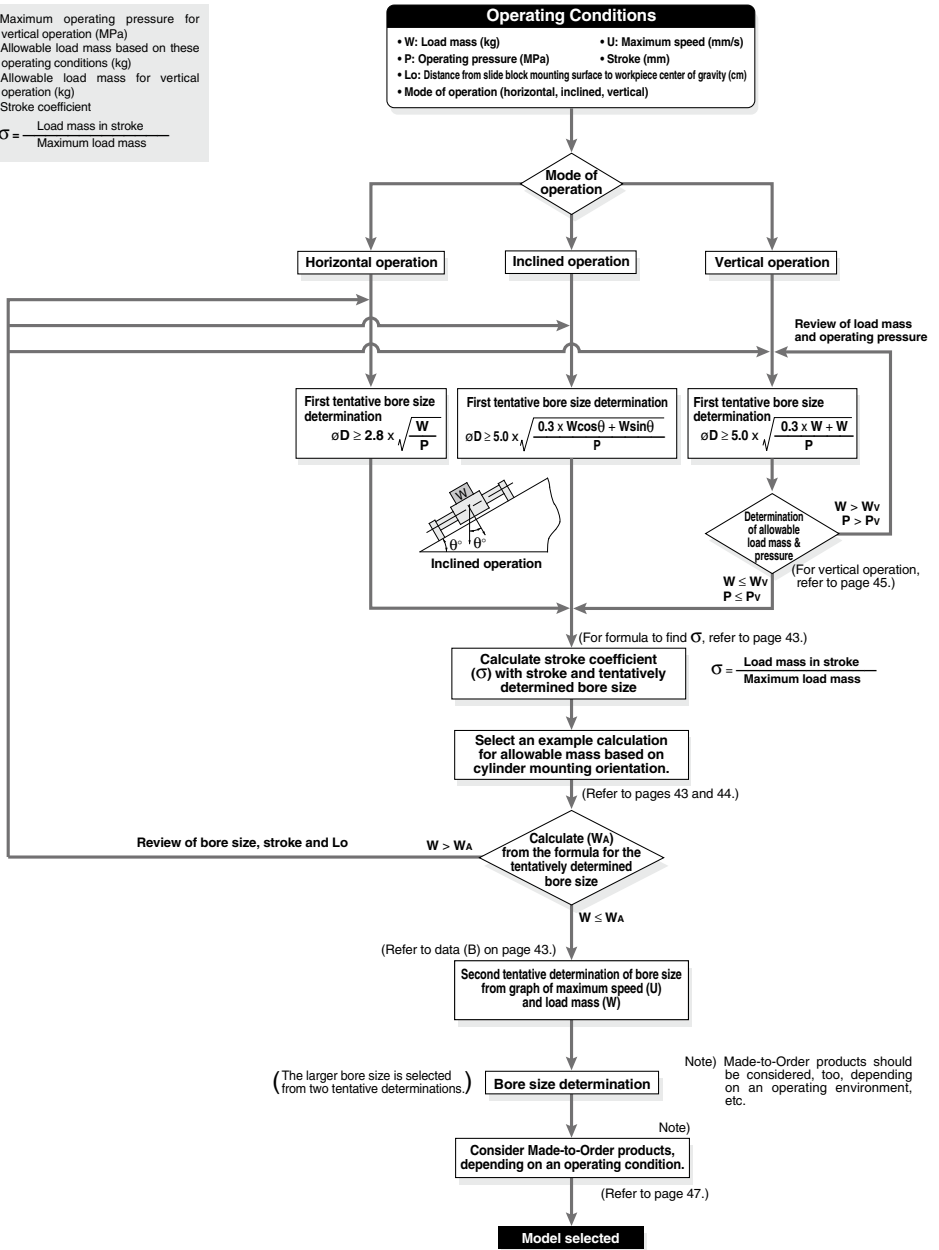

## Caution on Design 1

### How to Find $\sigma$ when Selecting the Allowable Load Mass

Since the maximum load mass with respect to the cylinder stroke length as shown in the table below,  $\sigma$  should be considered as a coefficient determined in accordance with each stroke.

Example) For REAS25-650

- (1) Maximum load mass = 20 kg
- (2) Load mass for 650 st = 13.6 kg
- (3)  $\sigma = \frac{13.6}{20} = 0.68$  is the result.

### Calculation Formula for $\sigma$ ( $\sigma \leq 1$ )

ST: Stroke (mm)

Model	REAS10	REAS15	REAS20
$\sigma =$	$\frac{10^{(0.86 - 1.3 \times 10^{-3} \times ST)}}{3}$	$\frac{10^{(1.5 - 1.3 \times 10^{-3} \times ST)}}{7}$	$\frac{10^{(1.71 - 1.3 \times 10^{-3} \times ST)}}{12}$

Model	REAS25	REAS32	REAS40
$\sigma =$	$\frac{10^{(1.98 - 1.3 \times 10^{-3} \times ST)}}{20}$	$\frac{10^{(2.26 - 1.3 \times 10^{-3} \times ST)}}{30}$	$\frac{10^{(2.48 - 1.3 \times 10^{-3} \times ST)}}{50}$

Note) Calculate with  $\sigma = 1$  for all applications up to  $\phi 10$ –300 mmST,  $\phi 15$ –500 mmST,  $\phi 20$ –500 mmST,  $\phi 25$ –500 mmST,  $\phi 32$ –600 mmST,  $\phi 40$ –600 mmST.

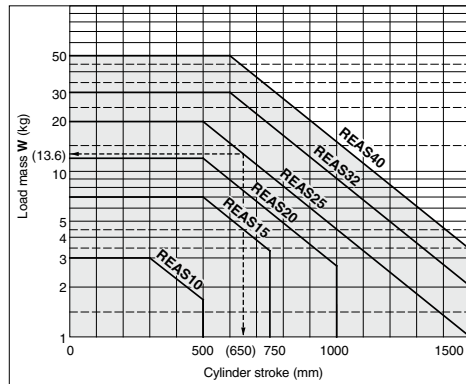

### <Data (B): Maximum Speed — Load Mass Chart>

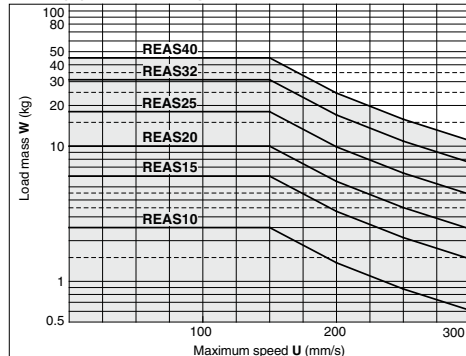

### Example of Allowable Load Mass Calculation Based on Cylinder Mounting Orientation

#### 1. Horizontal Operation (Floor mounting)

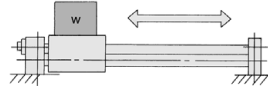

#### Maximum Load Mass (Center of slide block)

Bore size (mm)	10	15	20	25	32	40
Max. load mass (kg)	3	7	12	20	30	50
Stroke (Max.)	Up to 300st	Up to 500st	Up to 500st	Up to 500st	Up to 600st	Up to 600st

The above maximum load mass values will change with the stroke length for each cylinder size, due to limitation from warping of the guide shafts. (Take note of the coefficient  $\sigma$ .)

Moreover, depending on the operating direction, the allowable load mass may be different from the maximum load mass.

#### 2. Horizontal Operation (Wall mounting)

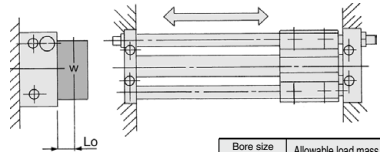

Lo: Distance from mounting surface to load center of gravity (cm)

Bore size (mm)	Allowable load mass $W_A$ (kg)
10	$\sigma \cdot 12.0$ $8.4 + 2L_o$
15	$\sigma \cdot 36.4$ $10.6 + 2L_o$
20	$\sigma \cdot 74.4$ $12 + 2L_o$
25	$\sigma \cdot 140$ $13.8 + 2L_o$
32	$\sigma \cdot 258$ $17 + 2L_o$
40	$\sigma \cdot 520$ $20.6 + 2L_o$

#### 3. Vertical Operation

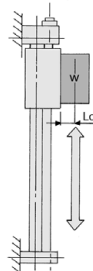

Lo: Distance from mounting surface to load center of gravity (cm)  
Note) Consider a safety factor for drop prevention.

Bore size (mm)	Allowable load mass $W_A$ (kg)
10	$\sigma \cdot 4.16$ $2.2 + L_o$
15	$\sigma \cdot 13.23$ $2.7 + L_o$
20	$\sigma \cdot 26.8$ $2.9 + L_o$
25	$\sigma \cdot 44.0$ $3.4 + L_o$
32	$\sigma \cdot 88.2$ $4.2 + L_o$
40	$\sigma \cdot 167.8$ $5.1 + L_o$

REA

REB

REC

Smooth

Low Speed

MQ

RHC

RZQ

D-□

-X□

## Caution on Design 2

### Example of Allowable Load Mass Calculation Based on Cylinder Mounting Orientation

#### 4. Inclined Operation (in operating direction)

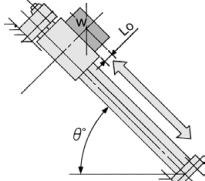

Angle	Up to 45°	Up to 60°	Up to 75°	Up to 90°
k	1	0.9	0.8	0.7

Angle coefficient (k): k = [up to 45° (= 0)] = 1,  
[up to 60°] = 0.9, [up to 75°] = 0.8,  
[up to 90°] = 0.7

Lo: Distance from mounting surface to load center of gravity (cm)

Bore size (mm)	Allowable load mass WA (kg)
10	$\sigma$ -10.5-K
	$3.5\cos\theta + 2(2.2 + Lo)\sin\theta$
15	$\sigma$ -35-K
	$5\cos\theta + 2(2.7 + Lo)\sin\theta$
20	$\sigma$ -72-K
	$6\cos\theta + 2(2.9 + Lo)\sin\theta$
25	$\sigma$ -120-K
	$6\cos\theta + 2(3.4 + Lo)\sin\theta$
32	$\sigma$ -210-K
	$7\cos\theta + 2(4.2 + Lo)\sin\theta$
40	$\sigma$ -400-K
	$8\cos\theta + 2(5.1 + Lo)\sin\theta$

#### 5. Inclined Operation (at a right angle to operating direction)

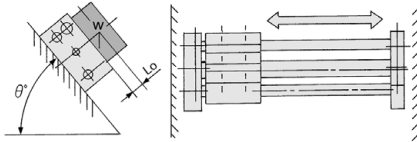

Lo: Distance from mounting surface to load center of gravity (cm)

Bore size (mm)	Allowable load mass WA (kg)
10	$\sigma$ -12.0
	$4 + 2(2.2 + Lo)\sin\theta$
15	$\sigma$ -36.4
	$5.2 + 2(2.7 + Lo)\sin\theta$
20	$\sigma$ -74.4
	$6.2 + 2(2.9 + Lo)\sin\theta$
25	$\sigma$ -140
	$7 + 2(3.4 + Lo)\sin\theta$
32	$\sigma$ -258
	$8.6 + 2(4.2 + Lo)\sin\theta$
40	$\sigma$ -520
	$10.4 + 2(5.1 + Lo)\sin\theta$

#### 6. Load Center Offset in Operating Direction (Lo)

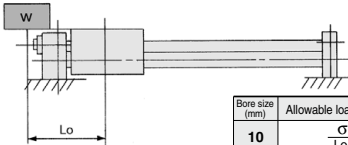

Lo: Distance from center of slide block to load's center of gravity (cm)

Bore size (mm)	Allowable load mass WA (kg)
10	$\sigma$ -5.25
	$Lo + 3.5$
15	$\sigma$ -17.5
	$Lo + 5.0$
20	$\sigma$ -36
	$Lo + 6.0$
25	$\sigma$ -60
	$Lo + 6.0$
32	$\sigma$ -105
	$Lo + 7.0$
40	$\sigma$ -200
	$Lo + 8.0$

#### 7. Horizontal Operation (Pushing load, Pusher)

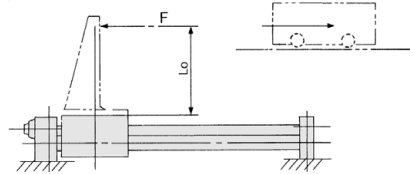

F: Drive (from slide block to position Lo) resistance force (kg)  
Lo: Distance from mounting surface to load center of gravity (cm)

Bore size (mm)	10	15	20
Allowable drive resisting force (FA) (kg)	$\frac{\sigma-5.25}{2.2 + Lo}$	$\frac{\sigma-17.5}{2.7 + Lo}$	$\frac{\sigma-36}{2.9 + Lo}$
Allowable drive resisting force (FA) (kg)	$\frac{\sigma-60}{3.4 + Lo}$	$\frac{\sigma-105}{4.2 + Lo}$	$\frac{\sigma-200}{5.1 + Lo}$

#### 8. Horizontal Operation (Load, Lateral offset Lo)

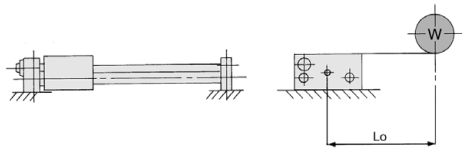

Lo: Distance from mounting surface to load center of gravity (cm)

Bore size (mm)	10	15	20
Allowable load mass WA (kg)	$\frac{\sigma-8.40}{4 + Lo}$	$\frac{\sigma-25.48}{5.2 + Lo}$	$\frac{\sigma-52.1}{6.2 + Lo}$
Allowable load mass WA (kg)	$\frac{\sigma-98}{7.0 + Lo}$	$\frac{\sigma-180}{8.6 + Lo}$	$\frac{\sigma-364}{10.4 + Lo}$

**Caution on Design 3**

**Vertical Operation**

When operating a load vertically, it should be operated within the allowable load mass and maximum operating pressures shown in the table below.

Use caution since operating above the prescribed values may lead to a dropping of the load with the magnetic coupling out of position.

When the cylinder is mounted vertically or sidelong, sliders may move downwards due to the self-weight or workpiece mass. If an accurate stopping position is required at the stroke end or the middle-stroke, use an external stopper to secure accurate positioning.

Bore size (mm)	Model	Allowable load mass Wv (kg)	Max. operating pressure Pv (MPa)
10	REAS10	2.7	0.55
15	REAS15	7.0	0.65
20	REAS20	11.0	0.65
25	REAS25	18.5	0.65
32	REAS32	30.0	0.65
40	REAS40	47.0	0.65

**Stroke Adjustment**

The adjusting bolt is adjusted to the optimum position for smooth acceleration and deceleration at the time of shipment, and should be operated at the full stroke. When stroke adjustment is necessary, the maximum amount of adjustment on one side is 2 mm. (Do not adjust more than 2 mm, as it will not be possible to obtain smooth acceleration and deceleration.)

**Stroke adjustment method**

Loosen the hexagon nut, and after performing the stroke adjustment from the plate side with a hexagon wrench, retighten and secure the hexagon nut.

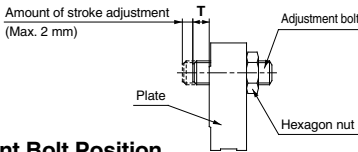

**Adjustment Bolt Position (at the time of shipment), Hexagon Nut Tightening Torque**

Model	T (mm)	Tightening torque (N·m)
REAS10	1	1.67
REAS15	1	
REAS20	1.5	3.14
REAS25	1.5	10.8
REAS32	3	23.5
REAS40	2	

**Intermediate Stop**

The cushion effect (smooth start-up, soft stop) exists only before the stroke end in the stroke ranges indicated in the table below.

The cushion effect (smooth start-up, soft stop) cannot be obtained in an intermediate stop or a return from an intermediate stop using an external stopper, etc.

**Cushion Stroke**

Model	Stroke (mm)
REAS10	20
REAS15	25
REAS20	30
REAS25	30
REAS32	30
REAS40	35

REA

REB

REC

Smooth

Low Speed

MQ

RHC

RZQ

D-□

-X□

# Sine Rodless Cylinder Slider Type/Slide Bearing **REAS Series** ø10, ø15, ø20, ø25, ø32, ø40

## How to Order

**REA S 25** - **300** - **J79W** -

• Sine rodless cylinder

• Slider type  
(Slide bearing)

• Bore size

10	10 mm
15	15 mm
20	20 mm
25	25 mm
32	32 mm
40	40 mm

• Port thread type

Symbol	Type	Bore size
Nil	M thread	ø10, ø15
	Rc	
TN	NPT	ø20, ø25, ø32, ø40
TF	G	

• Standard stroke

Refer to "Standard Stroke" on page 47.

• Made to Order Specification  
For details, refer to page 47.

• Number of auto switches

Nil	2 pcs.
S	1 pc.
n	"n" pcs.

• Auto switch

Nil	Without auto switch (Built-in magnet)
-----	---------------------------------------

\* For the applicable auto switch model, refer to the table below.

\* In cases without auto switches, there are switch rails only.

### Applicable Auto Switches

Refer to pages 941 to 1067 for further information on auto switches.

Type	Special function	Electrical entry	Indicator light	Wiring (Output)	Load voltage		Auto switch model		Lead wire length (m) <sup>*)</sup>				Pre-wired connector	Applicable load				
					DC	AC	Perpendicular	In-line	0.5 (Nil)	3 (L)	5 (Z)	None (N)						
Solid state auto switch	—	Grommet	No	3-wire (NPN)	5 V, 12 V	—	F7NV	F79	●	●	○	—	○	Relay, PLC				
				3-wire (PNP)			F7PV	F7P	●	●	○	—	○					
		Connector	2-wire	12 V	F7BV	J79	●	●	○	—	○							
	Diagnostic indication (2-color indicator)	Grommet	Yes	3-wire (NPN)	24 V	5 V, 12 V	—	J79C	—	●	●	●	●		—			
				3-wire (PNP)				F7NWV	F79W	●	●	○	—		○			
		Connector	2-wire	12 V	—	F7PW	—	●	●	○	—	○						
Water resistant (2-color indicator)	Grommet	No	4-wire (NPN)	5 V, 12 V	—	—	F7BWV	J79W	●	●	○	—	○					
							Connector	2-wire	12 V	—	F7BA**	—	●	●	○	—	○	
	With diagnostic output (2-color indicator)	—	—	—	—	—	—	F7BAV**	—	—	●	●	○	—	○			
Read auto switch	—	Grommet	Yes	3-wire (NPN equivalent)	24 V	5 V	—	A76H	—	—	—	—	—	—				
								Connector	2-wire	—	—	—	—	—	—	—	—	—
										—	—	—	—	—	—	—	—	—
		No	2-wire	—	—	—	—	200 V	A72	A72H	●	●	—	—	—			
				—	—	—	—	12 V	100 V	A73	A73H	●	●	●	—	—		
				—	—	—	—	5 V, 12 V	100 V or less	A80	A80H	●	●	—	—	○		
Yes	2-wire	—	—	—	—	12 V	—	—	—	●	●	●	—	—				
		—	—	—	—	5 V, 12 V	—	—	—	—	●	●	●	—	—			
No	2-wire	—	—	—	—	—	—	—	—	—	—	—	—	—				
No	2-wire	—	—	—	—	—	—	—	—	—	—	—	—	—				

\*\* Water resistant type auto switches can be mounted on the above models, but in such case SMC cannot guarantee water resistance. Consult with SMC regarding water resistant types with the above model numbers.

\* Lead wire length symbols: 0.5 m ..... Nil (Example) J79W  
3 m ..... L (Example) J79WL  
5 m ..... Z (Example) J79WZ  
None ..... N (Example) J79CN

\* Solid state auto switches marked with "○" are produced upon receipt of order.

- Since there are other applicable auto switches than listed, refer to page 52 for details.
- For details about auto switches with pre-wired connector, refer to pages 1014 and 1015.
- \* Auto switches are shipped together (not assembled).





**Symbol**

Air cushion  
(Magnet type)

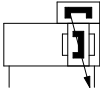

**Made to Order: Individual Specifications**  
(For details, refer to pages 112 and 113.)

Symbol	Specifications
-X168	Helical insert thread specifications
-X210	Non-lubricated exterior specifications
-X324	Non-lubricated exterior specifications with dust seal
-X431	Auto switch rails on both side faces (With 2 pcs.)

**Specifications**

Bore size (mm)	10	15	20	25	32	40
<b>Fluid</b>	Air					
<b>Proof pressure</b>	1.05 MPa					
<b>Maximum operating pressure</b>	0.7 MPa					
<b>Minimum operating pressure</b>	0.18 MPa					
<b>Ambient and fluid temperature</b>	-10 to 60°C (No freezing)					
<b>Piston speed (Max.)</b> <sup>Note)</sup>	50 to 300 mm/s					
<b>Lubrication</b>	Not required (Non-lube)					
<b>Stroke length tolerance (mm)</b>	0 to 250 st: $^{+1.0}_0$ , 251 to 1000 st: $^{+1.4}_0$ , 1001 st or longer: $^{+1.8}_0$					
<b>Holding force (N)</b>	53.9	137	231	363	588	922

Note) Piston speed above indicates the maximum speed. It takes approximately 0.5 seconds (for one side) after the slide block moves from the stroke end until it goes through the cushion stroke, while it takes approximately 1 second for both sides.

**Standard Stroke**

Bore size (mm)	Standard stroke (mm)	Maximum manufacturable stroke (mm)
<b>10</b>	150, 200, 250, 300	500
<b>15</b>	150, 200, 250, 300, 350, 400, 450, 500	750
<b>20</b>	200, 250, 300, 350, 400, 450, 500, 600, 700, 800	1000
<b>25</b>		1500
<b>32</b>		
<b>40</b>	200, 250, 300, 350, 400, 450, 500, 600, 700, 800, 900, 1000	1500

Note) Intermediate stroke is available in 1 mm increments.

**Weight**

Bore size (mm)	10	15	20	25	32	40
<b>Basic weight</b>	0.48	0.91	1.48	1.84	3.63	4.02
<b>Additional weight per each 50 mm of stroke</b>	0.074	0.104	0.138	0.172	0.267	0.406

Calculation: (Example) **REAS32-500** • Basic weight ..... 3.63 kg  
 • Additional weight ..... 0.267/50 st  
 • Cylinder stroke ..... 500 st  
 3.63 + 0.267 x 500 ÷ 50 = 6.3 kg

**REA**

**REB**

**REC**

**Smooth**

**Low Speed**

**MQ**

**RHC**

**RZQ**

**D-□**

**-X□**

# REAS Series

Construction:  $\phi 10, \phi 15$

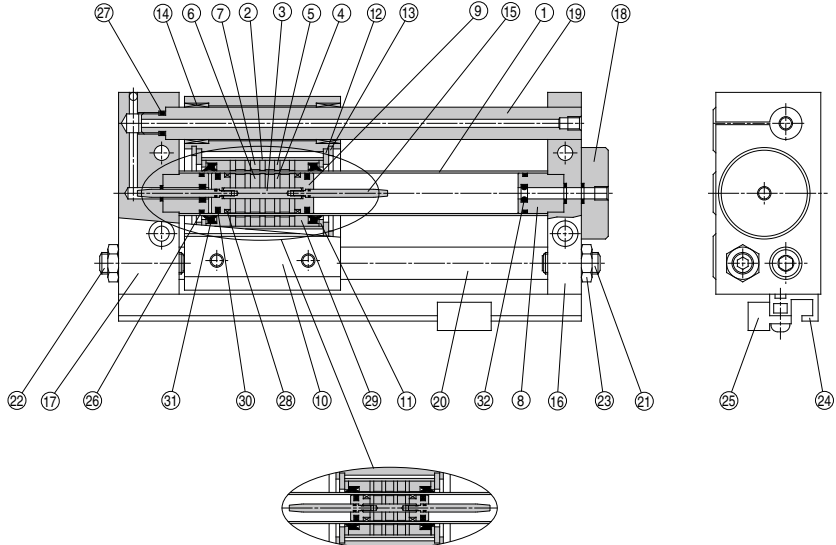

REAS10

## Component Parts

No.	Description	Material	Note
1	Cylinder tube	Stainless steel	
2	External slider tube	Aluminum alloy	
3	Shaft	Stainless steel	
4	Piston side yoke	Rolled steel plate	Zinc chromated
5	External slider side yoke	Rolled steel plate	Zinc chromated
6	Magnet A	—	
7	Magnet B	—	
8	Cushion seal holder	Aluminum alloy	Anodized
9	Piston	Aluminum alloy	Chromated
10	Slide block	Aluminum alloy	Hard anodized
11	Spacer	Rolled steel plate	Nickel plated
12	Slider spacer	Rolled steel plate	Nickel plated
13	Retaining ring	Carbon tool steel	Phosphate coated
14	Bushing	Oil retaining bearing material	
15	Cushion ring	Stainless steel	
16	Plate A	Aluminum alloy	Hard anodized

## Component Parts

No.	Description	Material	Note
17	Plate B	Aluminum alloy	Hard anodized
18	Port cover	Aluminum alloy	Hard anodized
19	Guide shaft A	Carbon steel	Hard chrome plated
20	Guide shaft B	Carbon steel	Hard chrome plated
21	Adjustment bolt A	Chromium molybdenum steel	Nickel plated
22	Adjustment bolt B	Chromium molybdenum steel	Nickel plated
23	Hexagon nut	Carbon steel	Nickel plated
24	Switch mounting rail	Aluminum alloy	
25	Auto switch	—	
26*	Cylinder tube gasket	NBR	
27*	Guide shaft gasket	NBR	
28*	Wear ring A	Special resin	
29*	Wear ring B	Special resin	
30*	Piston seal	NBR	
31*	Scraper	NBR	
32*	Cushion seal	NBR	

\* Seal kit includes 26 to 32. Order the seal kit, based on each bore size.

## Replacement Parts: Seal Kit

Bore size (mm)	Kit no.	Contents
10	REAS10-PS	Set of nos. above 26 27 28 29 30 31 32 (Note 1) Note 2)
15	REAS15-PS	Set of nos. above 26 27 28 29 30 31 32 (Note 1)

Note 1) It may be difficult to replace the cushion seal 32.

Note 2) For replacement of wear ring A 29 of  $\phi 10$ , please consult with SMC.

\* Seal kit includes a grease pack ( $\phi 10$ : 5 g and 10 g,  $\phi 15$ : 10 g).

Order with the following part number when only the grease pack is needed.

For  $\phi 10$  grease pack part no.: GR-F-005 (5 g) For external sliding part

GR-S-010 (10 g) For tube interior

For  $\phi 15$  grease pack part no.: GR-S-010 (10 g)

**Construction:  $\varnothing 20$  to  $\varnothing 40$**

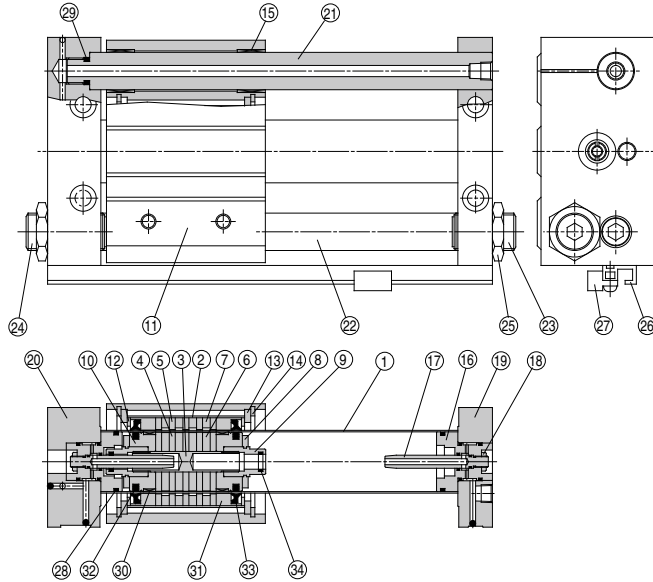

**Component Parts**

No.	Description	Material	Note
1	Cylinder tube	Stainless steel	
2	External slider tube	Aluminum alloy	
3	Shaft	Stainless steel	
4	Piston side yoke	Rolled steel plate	Zinc chromated
5	External slider side yoke	Rolled steel plate	Zinc chromated
6	Magnet A	—	
7	Magnet B	—	
8	Bumper	Urethane rubber	
9	Cushion seal holder	Aluminum alloy	Chromated
10	Piston	Aluminum alloy	Chromated
11	Slide block	Aluminum alloy	Hard anodized
12	Spacer	Rolled steel plate	Nickel plated
13	Slider spacer	Rolled steel plate	Nickel plated
14	Retaining ring	Carbon tool steel	Phosphate coated
15	Bushing	Oil retaining bearing material	
16	Cushion ring holder	Aluminum alloy	Anodized
17	Cushion ring	Brass	Electroless nickel plated (REAS32, 40)
		Stainless steel	REAS20, 25

**Component Parts**

No.	Description	Material	Note
18	Lock nut B	Carbon steel	Nickel plated
19	Plate A	Aluminum alloy	Hard anodized
20	Plate B	Aluminum alloy	Hard anodized
21	Guide shaft A	Carbon steel	Hard chrome plated
22	Guide shaft B	Carbon steel	Hard chrome plated
23	Adjustment bolt A	Chromium molybdenum steel	Nickel plated
24	Adjustment bolt B	Chromium molybdenum steel	Nickel plated
25	Hexagon nut	Carbon steel	Nickel plated
26	Switch mounting rail	Aluminum alloy	
27	Auto switch	—	With auto switch
28*	Cylinder tube gasket	NBR	
29*	Guide shaft gasket	NBR	
30*	Wear ring A	Special resin	
31*	Wear ring B	Special resin	
32*	Piston seal	NBR	
33*	Scraper	NBR	
34*	Cushion seal	NBR	

\* Seal kit includes ⑳ to ㉔. Order the seal kit, based on each bore size.

**Replacement Parts: Seal Kit**

Bore size (mm)	Kit no.	Contents
20	REAS20-PS	Set of nos. above ⑳ ㉑ ㉒ ㉓ ㉔ ㉕ ㉖ ㉗ ㉘ ㉙ ㉚ ㉛ ㉜ ㉝ ㉞ ㉟ ㊱ ㊲ ㊳ ㊴ ㊵ ㊶ ㊷ ㊸ ㊹ ㊺ ㊻ ㊼ ㊽ ㊾ ㊿
25	REAS25-PS	
32	REAS32-PS	
40	REAS40-PS	

Note) Cushion seal ㉔ may be difficult to be replaced.

\* Seal kit includes a grease pack (10 g).

Order with the following part number when only the grease pack is needed.

Grease pack part no.: GR-S-010 (10g)

REA

REB

REC

Smooth

Low Speed

MQ

RHC

RZQ

D-□

-X□

# REAS Series

**Dimensions:  $\phi 10$**

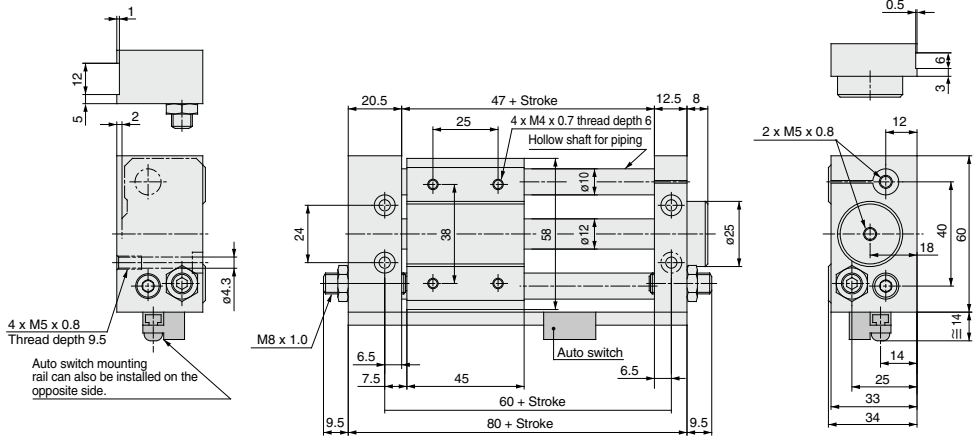

**Dimensions:  $\varnothing 15$  to  $\varnothing 40$**

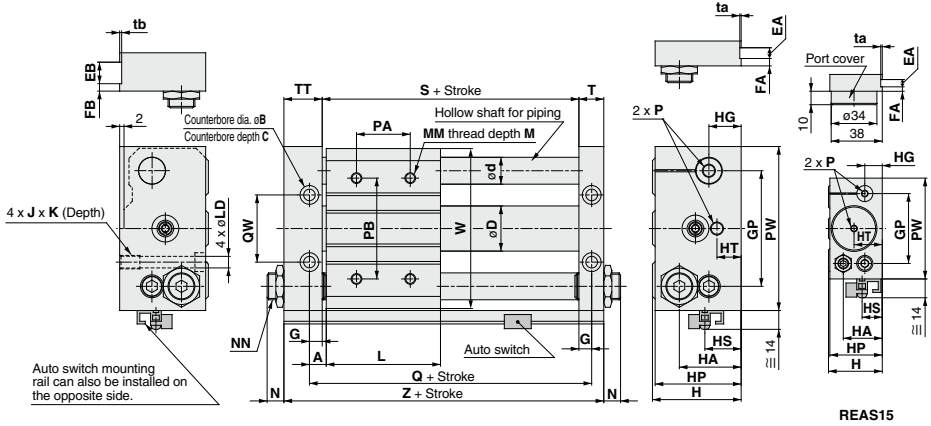

- REA
- REB
- REC
- Smooth
- Low Speed
- MQ
- RHC
- RZQ

(mm)

Model	A	B	C	D	d	EA	EB	FA	FB	G	GP	H	HA	HG
REAS15	7.5	9.5	5	16.6	12	6	13	3	6	6.5	52	40	29	13
REAS20	10	9.5	5	21.6	16	—	—	—	—	8.5	62	46	36	17
REAS25	10	11	6.5	26.4	16	8	14	4	7	8.5	70	54	40	20
REAS32	12.5	14	8	33.6	20	8	16	5	7	9.5	86	66	46	24
REAS40	12.5	14	8	41.6	25	10	20	5	10	10.5	104	76	57	25

Model	HP	HS	HT	J x K	L	LD	M	MM	N	NN
REAS15	39	15	21	M6 x 1.0 x 9.5	60	5.6	8	M5 x 0.8	7.5	M8 x 1.0
REAS20	45	25.5	10	M6 x 1.0 x 9.5	70	5.6	10	M6 x 1.0	9.5	M10 x 1.0
REAS25	53	23	10	M8 x 1.25 x 10	70	7	10	M6 x 1.0	11	M14 x 1.5
REAS32	64	27	17	M10 x 1.5 x 15	85	8.7	12	M8 x 1.25	11.5	M20 x 1.5
REAS40	74	31	14	M10 x 1.5 x 15	95	8.7	12	M8 x 1.25	10.5	M20 x 1.5

Model	P			PA*	PB	PW	Q	QW	S	T	TT	ta	tb	W	Z
	Nil	TN	TF												
REAS15	M5 x 0.8	—	—	30	50	75	75	30	62	12.5	22.5	0.5	1	72	97
REAS20	Rc 1/8	NPT 1/8	G 1/8	40	70	90	90	38	73	16.5	25.5	—	—	87	115
REAS25	Rc 1/8	NPT 1/8	G 1/8	40	70	100	90	42	73	16.5	25.5	0.5	—	97	115
REAS32	Rc 1/8	NPT 1/8	G 1/8	40	75	122	110	50	91	18.5	28.5	0.5	1	119	138
REAS40	Rc 1/4	NPT 1/4	G 1/4	65	105	145	120	64	99	20.5	35.5	1	1	142	155

\* PA dimensions are for split from center.

- D-□
- X□

# REAS Series Auto Switch Mounting

## Auto Switch Proper Mounting Position (Detection at Stroke End)

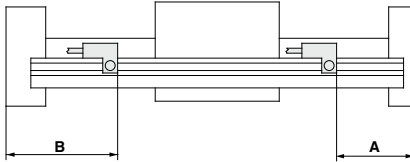

(mm)

Auto switch model Bore size (mm)	A dimension			B dimension		
	D-A73/A80	D-A72 D-A7□/A80H D-A73C/A80C D-F7□/J79 D-F7□W/J79W D-J79C D-F7□V/F□WV D-F7BA D-F79F	D-F7NT	D-A73/A80	D-A72 D-A7□/A80H D-A73C/A80C D-F7□/J79 D-F7□W/J79W D-J79C D-F7□V/F□WV D-F7BA D-F79F	D-F7NT
10	35	35.5	40.5	45	44.5	39.5
15	34.5	35	40	63	62	57.5
20	64.5	65	70	50.5	50	45
25	44	44.5	49.5	71.5	71	66
32	55	55.5	60.5	83.5	83	78
40	61	61.5	66.5	94.5	94	89

Note) Adjust the auto switch after confirming the operating conditions in the actual setting.

## Operating Range

(mm)

Auto switch model	Bore size (mm)					
	10	15	20	25	32	40
D-A7□, A8□	6	6	6	6	6	6
D-F7□, J7□, F79F	3	4	3	3	3	3.5

\* Since this is a guideline including hysteresis, not meant to be guaranteed. (assuming approximately ±30% dispersion)

There may be the case it will vary substantially depending on an ambient environment.

Other than the models listed in "How to Order", the following auto switches are applicable. For detailed specifications, refer to pages 941 to 1067.

Auto switch type	Model	Electrical entry (Fetching direction)	Features
Solid state	D-F7NT	Grommet (In-line)	With timer

\* For solid state auto switches, auto switches with a pre-wired connector are also available. Refer to pages 1014 and 1015 for details.



# REAS Series Specific Product Precautions

Be sure to read this before handling the products. Refer to back page 50 for Safety Instructions and pages 3 to 12 for Actuator and Auto Switch Precautions.

## Operation

### Warning

- 1. Be aware of the space between the plates and the slide block.**  
Take sufficient care to avoid getting your hands or fingers caught when the cylinder is operated.
- 2. Do not apply a load to a cylinder which is greater than the allowable value stated in the "Model Selection" pages.**  
It may cause malfunction.
- 3. Consult with SMC when the cylinder is operated in an environment in which the cylinder is exposed to cutting fluid or water, or the cylinder sliding part lubrication deteriorates.**
- 4. When applying grease to the cylinder, use the grease already used for the product. Contact SMC, grease packs are available.**

## Mounting

### Caution

- 1. Avoid operation with the external slider fixed to the mounting surface.**  
The cylinder should be operated with the plates fixed to the mounting surface.
- 2. Make sure that the cylinder mounting surface has a flatness of 0.2 mm or less.**  
If the flatness of a workpiece is not appropriate, it may adversely affect the operation since two guide shafts will be twisted. Furthermore, the increase of the sliding resistance and early abrasion of bearings may shorten the service life.  
  
The cylinder mounting surface must have a flatness of 0.2 mm or less, and the cylinder must be mounted so as to be smoothly operated with a minimum operating pressure (0.18 MPa or less) for a full stroke.

## Disassembly and Maintenance

### Warning

- 1. Use caution, the attractive force of the magnets is very strong.**  
When removing the external slider and piston slider from the cylinder tube for maintenance, etc., handle with caution since the magnet installed in each slider has a very strong attractive force.

### Caution

- 1. Use caution when taking off the external slider, since the piston slider will be directly attracted to it.**  
When removing the external slider or piston slider from the cylinder tube, first force the sliders out of their magnetically coupled positions, and then remove them individually when there is no longer any holding force. If they are removed while still magnetically coupled, they will be directly attracted to one another and will not come apart.
- 2. Do not disassemble the magnetic components (piston and external sliders).**  
This may cause a loss of holding force and malfunction.

REA

REB

REC

Smooth

Low  
Speed

MQ

RHC

RZQ

D-□

-X□





# Slider Type/Ball Bushing Bearing

## *REAL Series*

ø10, ø15, ø20, ø25, ø32, ø40

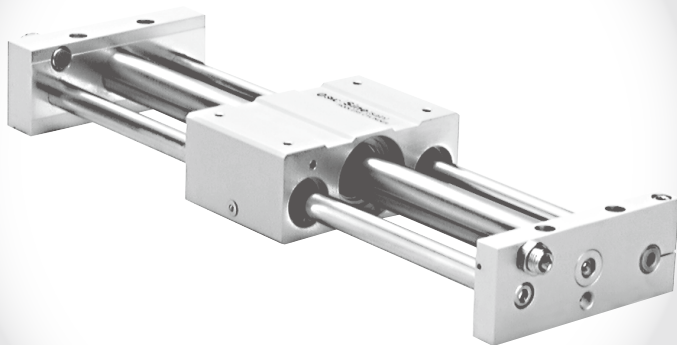

REA

REB

REC

Smooth

Low  
Speed

MQ

RHC

RZQ

D-□

-X□

# REAL Series Model Selection

Pv: Maximum operating pressure for vertical operation (MPa)  
 WA: Allowable load mass based on these operating conditions (kg)  
 Wv: Allowable load mass for vertical operation (kg)  
 σ: Stroke coefficient  

$$\sigma = \frac{\text{Load mass in stroke}}{\text{Maximum load mass}}$$

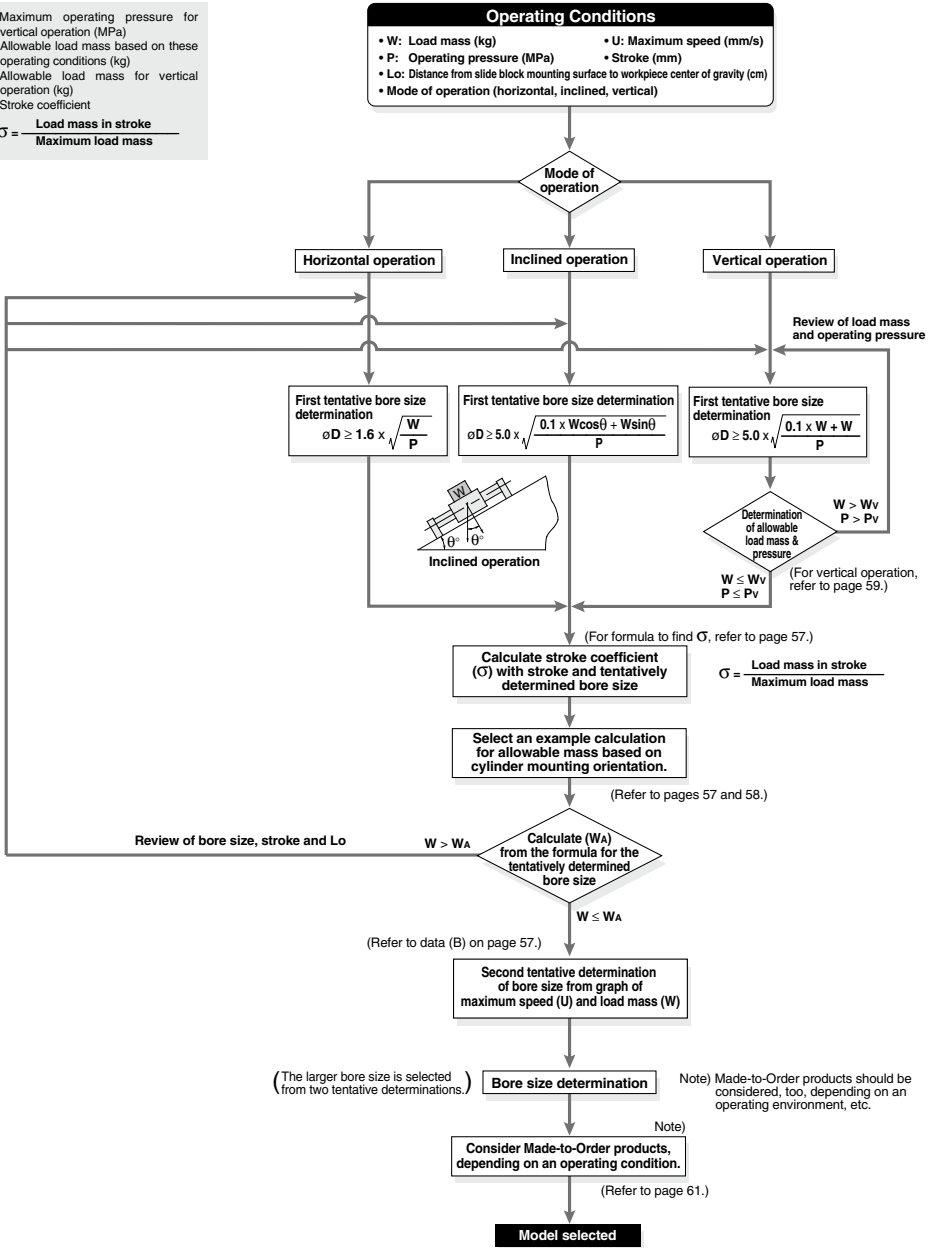

## Caution on Design 1

### How to Find $\sigma$ when Selecting the Allowable Load Mass

Since the maximum load mass with respect to the cylinder stroke changes as shown in the table below,  $\sigma$  should be considered as a coefficient determined in accordance with each stroke.

Example) For REAL25-650

- (1) Maximum load mass = 20 kg
- (2) Load mass for 650 st = 13.6 kg
- (3)  $S = \frac{13.6}{20} = 0.68$  is the result.

### Calculation Formula for $\sigma$ ( $\sigma \leq 1$ )

ST: Stroke (mm)

Model	REAL10	REAL15	REAL20
$\sigma =$	$\frac{10^{(0.86 - 1.3 \times 10^{-3} \times ST)}}{3}$	$\frac{10^{(1.5 - 1.3 \times 10^{-3} \times ST)}}{7}$	$\frac{10^{(1.71 - 1.3 \times 10^{-3} \times ST)}}{12}$

Model	REAL25	REAL32	REAL40
$\sigma =$	$\frac{10^{(1.98 - 1.3 \times 10^{-3} \times ST)}}{20}$	$\frac{10^{(2.26 - 1.3 \times 10^{-3} \times ST)}}{30}$	$\frac{10^{(2.46 - 1.3 \times 10^{-3} \times ST)}}{50}$

Note) Calculate with  $\sigma = 1$  for all applications up to  $\phi 10$ –300 mmST,  $\phi 15$ –500 mmST,  $\phi 20$ –500 mmST,  $\phi 25$ –500 mmST,  $\phi 32$ –600 mmST,  $\phi 40$ –600 mmST.

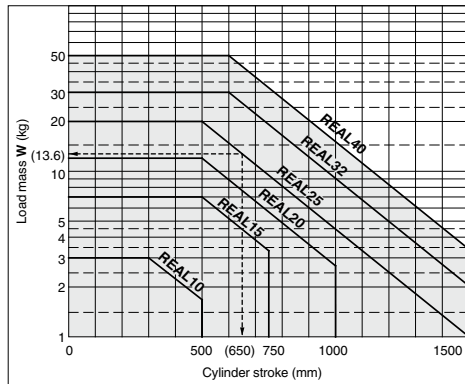

### <Data (B): Maximum Speed — Load Mass Chart>

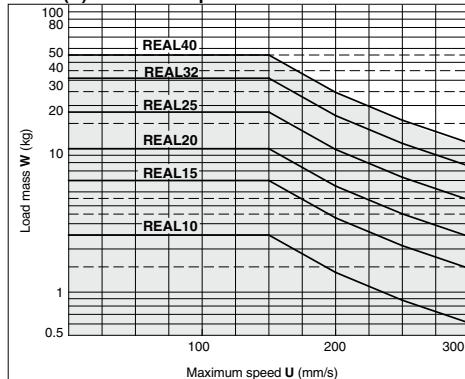

### Examples of Allowable Load Mass Calculation Based on Cylinder Mounting Orientation

#### 1. Horizontal Operation (Floor mounting)

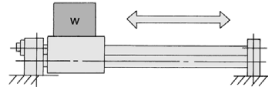

#### Maximum Load Mass (Center of slide block)

(kg)

Bore size (mm)	10	15	20	25	32	40
Maximum load mass (kg)	3	7	12	20	30	50
Stroke (max)	Up to 300 st	Up to 500 st	Up to 500 st	Up to 500 st	Up to 600 st	Up to 600 st

The above maximum load mass values will change with the stroke length for each cylinder size, due to limitation from warping of the guide shafts. (Take note of the coefficient  $\sigma$ .)

Moreover, depending on the operating direction, the allowable load mass may be different from the maximum load mass.

#### 2. Horizontal Operation (Wall mounting)

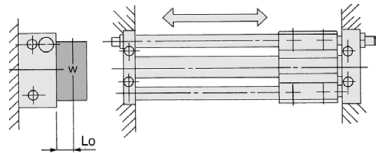

Lo: Distance from mounting surface to load center of gravity (cm)

Bore size (mm)	Allowable load mass $W_A$ (kg)
10	$\sigma - 15.0$ $8.9 + 2Lo$
15	$\sigma - 45.5$ $11.3 + 2Lo$
20	$\sigma - 101$ $13.6 + 2Lo$
25	$\sigma - 180$ $15.2 + 2Lo$
32	$\sigma - 330$ $18.9 + 2Lo$
40	$\sigma - 624$ $22.5 + 2Lo$

#### 3. Vertical Operation

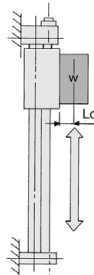

Lo: Distance from mounting surface to load center of gravity (cm)  
Note) Consider a safety factor for drop prevention.

Bore size (mm)	Allowable load mass $W_A$ (kg)
10	$\sigma - 5.00$ $1.95 + Lo$
15	$\sigma - 15.96$ $2.4 + Lo$
20	$\sigma - 31.1$ $2.8 + Lo$
25	$\sigma - 54.48$ $3.1 + Lo$
32	$\sigma - 112.57$ $3.95 + Lo$
40	$\sigma - 212.09$ $4.75 + Lo$

REA

REB

REC

Smooth

Low Speed

MQ

RHC

RZQ

## Caution on Design 2

### Examples of Allowable Load Mass Calculation Based on Cylinder Mounting Orientation

#### 4. Inclined Operation (in operating direction)

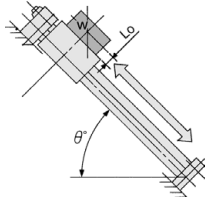

Angle	up to 45°	up to 60°	up to 75°	up to 90°
k	1	0.9	0.8	0.7

Angle coefficient (k): k = [up to 45° (= θ)] = 1,  
[up to 60°] = 0.9, [up to 75°] = 0.8,  
[up to 90°] = 0.7

Lo: Distance from mounting surface to load center of gravity (cm)

Bore size (mm)	Allowable load mass WA (kg)
10	$\sigma$ -10.2-K
	$2.8\cos\theta + 2(1.95 + Lo)\sin\theta$
15	$\sigma$ -31.1-K
	$2.9\cos\theta + 2(2.4 + Lo)\sin\theta$
20	$\sigma$ -86.4-K
	$6\cos\theta + 2(2.8 + Lo)\sin\theta$
25	$\sigma$ -105.4-K
	$3.55\cos\theta + 2(3.1 + Lo)\sin\theta$
32	$\sigma$ -178-K
	$4\cos\theta + 2(3.95 + Lo)\sin\theta$
40	$\sigma$ -361.9-K
	$5.7\cos\theta + 2(4.75 + Lo)\sin\theta$

#### 5. Inclined Operation (at a right angle to operating direction)

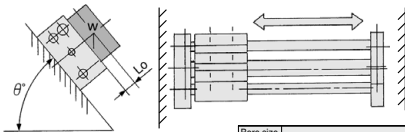

Lo: Distance from mounting surface to load center of gravity (cm)

Bore size (mm)	Allowable load mass WA (kg)
10	$\sigma$ -15
	$5 + 2(1.95 + Lo)\sin\theta$
15	$\sigma$ -45.5
	$6.5 + 2(2.4 + Lo)\sin\theta$
20	$\sigma$ -115
	$8 + 2(2.8 + Lo)\sin\theta$
25	$\sigma$ -180
	$9 + 2(3.1 + Lo)\sin\theta$
32	$\sigma$ -330
	$11 + 2(3.95 + Lo)\sin\theta$
40	$\sigma$ -624
	$13 + 2(4.75 + Lo)\sin\theta$

#### 6. Load Center Offset in Operating Direction (Lo)

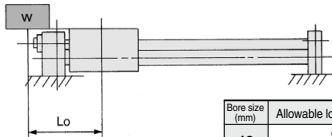

Lo: Distance from center of slide block to load center of gravity (cm)

Bore size (mm)	Allowable load mass WA (kg)
10	$\sigma$ -5.6
	$Lo + 2.8$
15	$\sigma$ -13.34
	$Lo + 2.9$
20	$\sigma$ -43.2
	$Lo + 6$
25	$\sigma$ -46.15
	$Lo + 3.55$
32	$\sigma$ -80
	$Lo + 4$
40	$\sigma$ -188.1
	$Lo + 5.7$

#### 7. Horizontal Operation (Pushing load, Pusher)

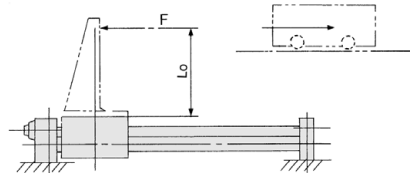

F: Drive (from slide block to position Lo) resistance force (kg)  
Lo: Distance from mounting surface to load center of gravity (cm)

Bore size (mm)	10	15	20
Allowable drive resisting force (FA) (kg)	$\sigma$ -5.55	$\sigma$ -15.96	$\sigma$ -41.7
	$1.95 + Lo$	$2.4 + Lo$	$2.8 + Lo$

Bore size (mm)	25	32	40
Allowable drive resisting force (FA) (kg)	$\sigma$ -58.9	$\sigma$ -106.65	$\sigma$ -228
	$3.1 + Lo$	$3.95 + Lo$	$4.75 + Lo$

#### 8. Horizontal Operation (Load, Lateral offset Lo)

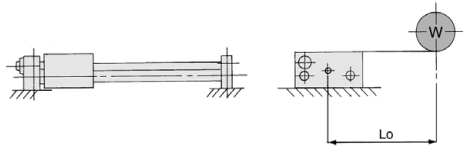

Lo: Distance from center of side block to load's center of gravity (cm)

Bore size (mm)	10	15	20
Allowable load mass WA (kg)	$\sigma$ -15	$\sigma$ -45.5	$\sigma$ -80.7
	$5 + Lo$	$6.5 + Lo$	$8 + Lo$

Bore size (mm)	25	32	40
Allowable load mass WA (kg)	$\sigma$ -144	$\sigma$ -275	$\sigma$ -520
	$9 + Lo$	$11 + Lo$	$13 + Lo$

**Caution on Design 3**

**Vertical Operation**

When operating a load vertically, it should be operated within the allowable load weights and maximum operating pressures shown in the table below.

Use caution since operating above the prescribed values may lead to a dropping of the load with the magnetic coupling out of position.

When the cylinder is mounted vertically or sidelong, sliders may move downwards due to the self-weight or workpiece mass. If an accurate stopping position is required at the stroke end or the middle-stroke, use an external stopper to secure accurate positioning.

Bore size (mm)	Model	Allowable load mass Wv (kg)	Maximum operating pressure Pv (MPa)
10	REAL10	2.7	0.55
15	REAL15	7.0	0.65
20	REAL20	11.0	0.65
25	REAL25	18.5	0.65
32	REAL32	30.0	0.65
40	REAL40	47.0	0.65

**Intermediate Stop**

The cushion effect (smooth start-up, soft stop) exists only before the stroke end in the stroke ranges indicated in the table below.

The cushion effect (smooth start-up, soft stop) cannot be obtained in an intermediate stop or return from an intermediate stop using an external stopper, etc.

**Cushion Stroke**

Model	Stroke (mm)
REAL10	20
REAL15	25
REAL20	30
REAL25	30
REAL32	30
REAL40	35

**Stroke Adjustment**

The adjusting bolt is adjusted to the optimum position for smooth acceleration and deceleration at the time of shipment, and should be operated at the full stroke. When stroke adjustment is necessary, the maximum amount of adjustment on one side is 2 mm. (Do not adjust more than 2 mm, as it will not be possible to obtain smooth acceleration and deceleration.)

**Stroke adjustment method**

Loosen the hexagon nut, and after performing the stroke adjustment from the plate side with a hexagon wrench, retighten and secure the hexagon nut.

Amount of stroke adjustment (Max. 2 mm)

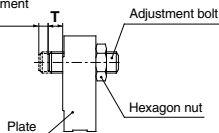

**Adjustment Bolt Position (at the time of shipment), Hexagon Nut Tightening Torque**

Model	T (mm)	Tightening torque (N-m)
REAL10	1	1.67
REAL15	1	
REAL20	1	3.14
REAL25	1	10.8
REAL32	1	23.5
REAL40	1	

- REA**
- REB**
- REC**
- Smooth
- Low Speed
- MQ**
- RHC**
- RZQ**

- D-□**
- X□**

# Sine Rodless Cylinder Slider Type/Ball Bushing Bearing

## REAL Series

ø10, ø15, ø20, ø25, ø32, ø40

### How to Order

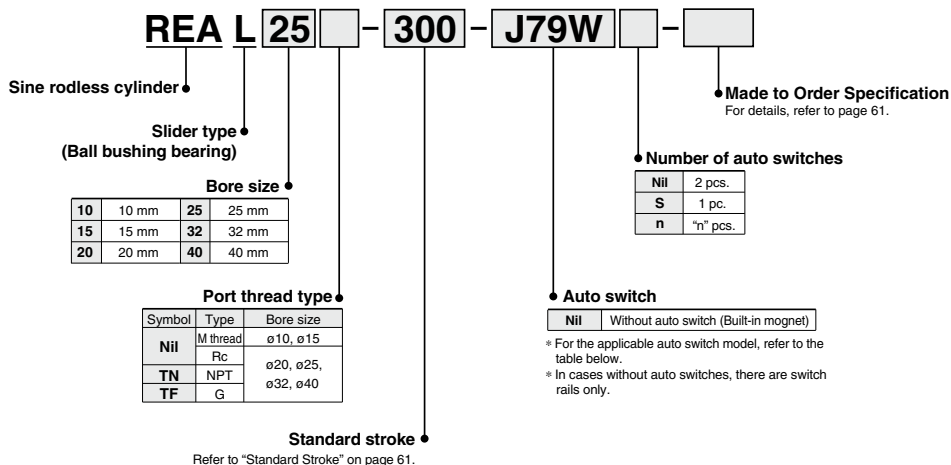

\* For the applicable auto switch model, refer to the table below.

\* In cases without auto switches, there are switch rails only.

### Applicable Auto Switches

Refer to pages 941 to 1067 for further information on auto switches.

Type	Special function	Electrical entry	Indicator light	Wiring (Output)	Load voltage		Auto switch model		Lead wire length (m) *				Pre-wired connector	Applicable load				
					DC	AC	Perpendicular	In-line	0.5	3	5	None						
									(Nil)	(L)	(Z)	(N)						
Solid state auto switch	—	Grommet	No	3-wire (NPN)	5 V, 12 V	—	F7NV	F79	●	●	○	—	○	IC circuit				
				3-wire (PNP)			F7PV	F7P	●	●	○	—	○					
	Diagnostic indication (2-color indicator)	Connector	No	2-wire	12 V	—	F7BV	J79	●	●	○	—	○	—				
							J79C	—	●	●	●	●	—					
		Grommet	Yes	3-wire (NPN)	24 V	5 V, 12 V	—	F7NWX	F79W	●	●	○	—	○	IC circuit			
				3-wire (PNP)				—	F7PW	●	●	○	—	○				
Water resistant (2-color indicator)	Grommet	No	2-wire	12 V	—	F7BWX	J79W	●	●	○	—	○	—					
						—	F7BA**	—	●	○	—	○						
With diagnostic output (2-color indicator)	Grommet	No	4-wire (NPN)	5 V, 12 V	—	—	F79F	●	●	○	—	○	IC circuit					
						—	A76H	●	●	—	—	—						
Reed auto switch	—	Grommet	Yes	3-wire (NPN equivalent)	—	5 V	—	A76H	●	●	—	—	—	IC circuit				
							—	A72	A72H	●	●	—	—		—			
		Connector	No	Yes	2-wire	24 V	12 V	100 V	A73	A73H	●	●	●	—	—	Relay, PLC		
										A80	A80H	●	●	—	—		—	
										A73C	—	●	●	●	—		—	—
										A80C	—	●	●	●	—		—	—
	No		5 V, 12 V	—	—	—	—	—	—	—	—	—						

\*\* Water resistant type auto switches can be mounted on the above models, but in such case SMC cannot guarantee water resistance. Consult with SMC regarding water resistant types with the above model numbers.

\* Lead wire length symbols: 0.5 m ..... Nil (Example) J79W  
 3 m ..... L (Example) J79WL  
 5 m ..... Z (Example) J79WZ  
 None ..... N (Example) J79CN

\* Solid state auto switches marked with "○" are produced upon receipt of order.

- Since there are other applicable auto switches than listed, refer to page 66 for details.
- For details about auto switches with pre-wired connector, refer to pages 1014 and 1015.
- Auto switches are shipped together (not assembled).

# Sine Rodless Cylinder Slider Type/Ball Bushing Bearing **REAL Series**



### Symbol

Air cushion  
(Magnet type)



**Made to Order: Individual Specifications**  
(For details, refer to pages 112 and 113.)

Symbol	Specifications
-X168	Helical insert thread specifications
-X431	Auto switch rails on both side faces (With 2 pcs.)

## Specifications

Bore size (mm)	10	15	20	25	32	40
<b>Fluid</b>	Air					
<b>Proof pressure</b>	1.05 MPa					
<b>Maximum operating pressure</b>	0.7 MPa					
<b>Minimum operating pressure</b>	0.18 MPa					
<b>Ambient and fluid temperature</b>	-10 to 60°C (No freezing)					
<b>Piston speed (Max.)</b> <sup>Note</sup>	50 to 300 mm/s					
<b>Lubrication</b>	Not required (Non-lube)					
<b>Stroke length tolerance (mm)</b>	0 to 250 st: $^{+1.0}_0$ , 251 to 1000 st: $^{+1.4}_0$ , 1001 st or longer: $^{+1.8}_0$					
<b>Holding force (N)</b>	53.9	137	231	363	588	922

Note) Piston speed above indicates the maximum speed. It takes approximately 0.5 seconds (for one side) after the slide block moves from the stroke end until it goes through the cushion stroke, while it takes approximately 1 second for both sides.

## Standard Stroke

Bore size (mm)	Standard stroke (mm)	Maximum manufacturable stroke (mm)
<b>10</b>	150, 200, 250, 300	500
<b>15</b>	150, 200, 250, 300, 350, 400, 450, 500	750
<b>20</b>	200, 250, 300, 350, 400, 450, 500, 600, 700, 800	1000
<b>25</b>		1500
<b>32</b>		
<b>40</b>	200, 250, 300, 350, 400, 450, 500, 600, 700, 800, 900, 1000	1500

Note) Intermediate stroke is available in 1 mm increments.

## Weight

Bore size (mm)	10	15	20	25	32	40
<b>Basic weight</b>	0.580	1.10	1.85	2.21	4.36	4.83
<b>Additional weight per each 50 mm of stroke</b>	0.077	0.104	0.138	0.172	0.267	0.406

Calculation: (Example) **REAL32-500**

- Basic weight ..... 4.36 kg
- Additional weight ..... 0.267/50 st
- Cylinder stroke ..... 500 st
- 4.36 + 0.267 x 500 ÷ 50 = 7.03 kg

REA

REB

REC

Smooth

Low Speed

MQ

RHC

RZQ

D-□

-X□

# REAL Series

Construction:  $\phi 10, \phi 15$

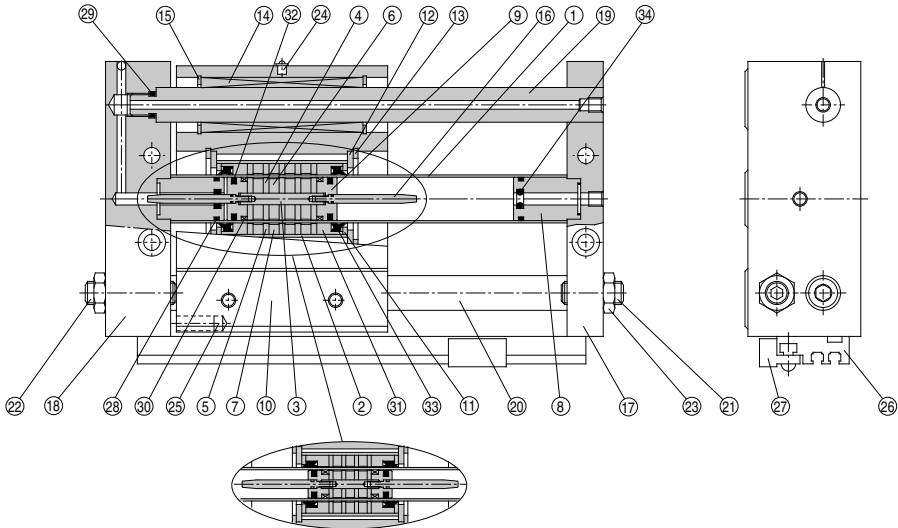

## REAL10

### Component Parts

No.	Description	Material	Note
1	Cylinder tube	Stainless steel	
2	External slider tube	Aluminum alloy	
3	Shaft	Stainless steel	
4	Piston side yoke	Rolled steel plate	Zinc chromated
5	External slider side yoke	Rolled steel plate	Zinc chromated
6	Magnet A	—	
7	Magnet B	—	
8	Cushion seal holder	Aluminum alloy	Anodized
9	Piston	Aluminum alloy	Chromated
10	Slide block	Aluminum alloy	Hard anodized
11	Spacer	Rolled steel plate	Nickel plated
12	Slider spacer	Rolled steel plate	Nickel plated
13	Retaining ring	Carbon tool steel	Phosphate coated
14	Ball bushing	—	
15	Retaining ring	Carbon tool steel	Phosphate coated
16	Cushion ring	Stainless steel	
17	Plate A	Aluminum alloy	Hard anodized

### Component Parts

No.	Description	Material	Note
18	Plate B	Aluminum alloy	Hard anodized
19	Guide shaft A	Carbon steel	Hard chrome plated
20	Guide shaft B	Carbon steel	Hard chrome plated
21	Adjustment bolt A	Chromium molybdenum steel	Nickel plated
22	Adjusting nut B	Chromium molybdenum steel	Nickel plated
23	Hexagon nut	Carbon steel	Nickel plated
24	Grease nipple	Carbon steel	Nickel plated (Except REAL10)
25	Magnet for auto switch	—	
26	Switch mounting rail	Aluminum alloy	
27	Auto switch	—	
28*	Cylinder tube gasket	NBR	
29*	Guide shaft gasket	NBR	
30*	Wear ring A	Special resin	
31*	Wear ring B	Special resin	
32*	Piston seal	NBR	
33*	Scraper	NBR	
34*	Cushion seal	NBR	

\* Seal kit includes 28 to 34. Order the seal kit, based on each bore size.

### Replacement Parts: Seal Kit

Bore size (mm)	Kit no.	Contents
10	REAL10-PS	Set of nos. above 28 29 30 31 32 33 34 Note 1) Note 2)
15	REAS15-PS	Set of nos. above 28 29 30 31 32 33 34 Note 1)

Note 1) It may be difficult to replace the cushion seal 34.

Note 2) For replacement of wear ring A 30 of  $\phi 10$ , please consult with SMC.

\* Seal kit includes a grease pack ( $\phi 10$ : 5 g and 10 g,  $\phi 15$ : 10 g).

Order with the following part number when only the grease pack is needed.

For  $\phi 10$  grease pack part no.: GR-F-005 (5 g) For external sliding part  
GR-S-010 (10 g) For tube interior

For  $\phi 15$  grease pack part no.: GR-S-010 (10 g)



**Construction:  $\varnothing 20$  to  $\varnothing 40$**

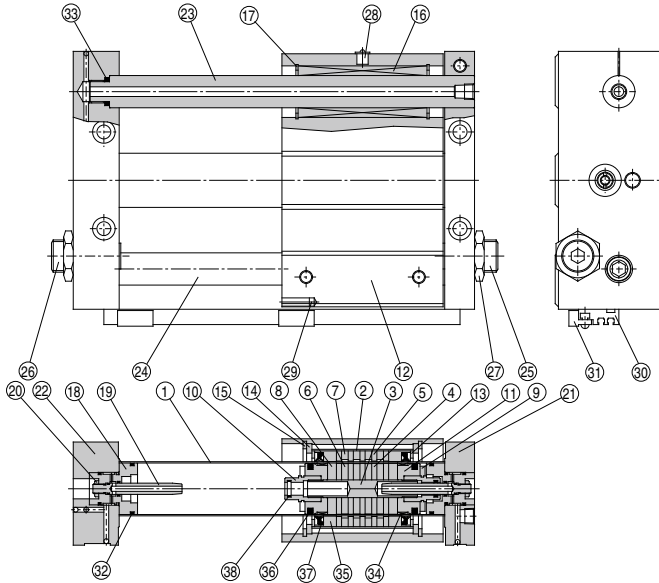

**Component Parts**

No.	Description	Material	Note
1	Cylinder tube	Stainless steel	
2	External slider tube	Aluminum alloy	
3	Shaft	Stainless steel	
4	Piston side yoke	Rolled steel plate	Zinc chromated
5	External slider side yoke	Rolled steel plate	Zinc chromated
6	Magnet A	—	
7	Magnet B	—	
8	Piston side spacer	Aluminum alloy	Chromated
9	Bumper	Urethane rubber	
10	Cushion seal holder	Aluminum alloy	Chromated
11	Piston	Aluminum alloy	Chromated
12	Slide block	Aluminum alloy	Hard anodized
13	Spacer	Rolled steel plate	Nickel plated
14	Slider spacer	Carbon steel	Nickel plated
15	Retaining ring	Carbon tool steel	Phosphate coated
16	Ball bushing	—	
17	Retaining ring	Carbon tool steel	Phosphate coated
18	Cushion ring holder	Aluminum alloy	Anodized
19	Cushion ring	Brass	Electroless nickel plated (REAL32, 40)
		Stainless steel	REAL20, 25

**Component Parts**

No.	Description	Material	Note
20	Lock nut B	Carbon steel	Nickel plated
21	Plate A	Aluminum alloy	Hard anodized
22	Plate B	Aluminum alloy	Hard anodized
23	Guide shaft A	Carbon steel	Hard chrome plated
24	Guide shaft B	Carbon steel	Hard chrome plated
25	Adjustment bolt A	Chromium molybdenum steel	Nickel plated
26	Adjustment bolt B	Chromium molybdenum steel	Nickel plated
27	Hexagon nut	Carbon steel	Nickel plated
28	Grease nipple	Brass	Nickel plated
29	Magnet for auto switch	—	
30	Switch mounting rail	Aluminum alloy	
31	Auto switch	—	
32*	Cylinder tube gasket	NBR	
33*	Guide shaft gasket	NBR	
34*	Wear ring A	Special resin	
35*	Wear ring B	Special resin	
36*	Piston seal	NBR	
37*	Scraper	NBR	
38*	Cushion seal	NBR	

\* Seal kit includes ②② to ③③. Order the seal kit, based on each bore size.

**Replacement Parts: Seal Kit**

Bore size (mm)	Kit no.	Contents
20	REAS20-PS	Set of nos. above ③② ③③ ③④ ③⑤ ③⑥ ③⑦ ③⑧
25	REAS25-PS	
32	REAS32-PS	
40	REAS40-PS	

Note) It may be difficult to replace the cushion seal ③⑧.

\* Seal kit includes a grease pack (10 g).

Order with the following part number when only the grease pack is needed.

Grease pack part no.: GR-S-010 (10 g)

- REA
- REB
- REC
- Smooth
- Low Speed
- MQ
- RHC
- RZQ

- D-□
- X□

# REAL Series

Dimensions:  $\phi 10$

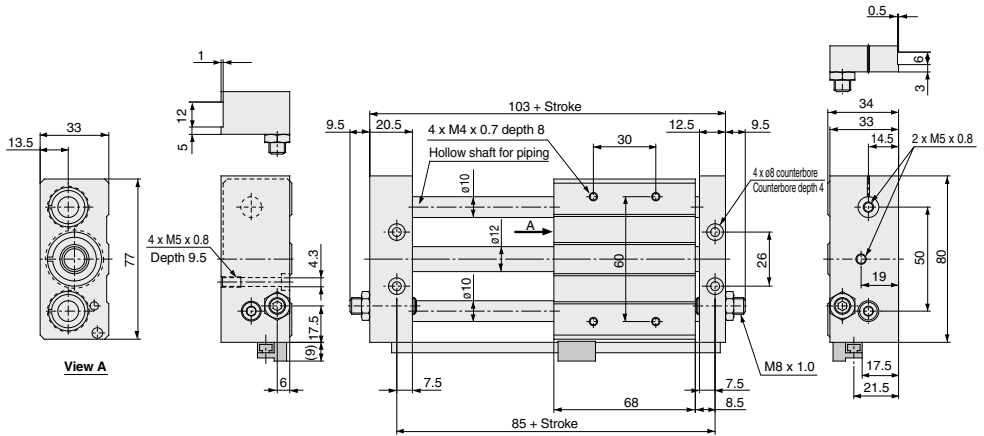

Sine Rodless Cylinder  
Slider Type/Ball Bushing Bearing **REAL Series**

Dimensions:  $\phi 15$  to  $\phi 40$

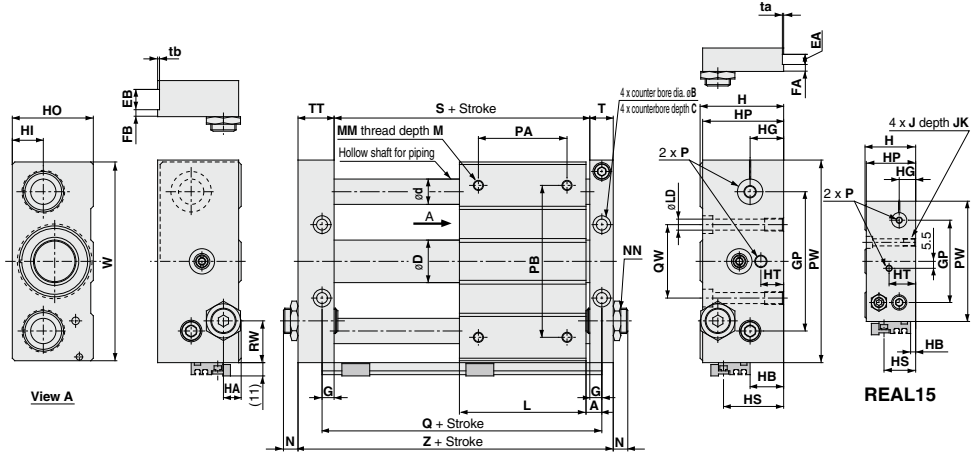

- REA**
- REB**
- REC**
- Smooth
- Low Speed
- MQ**
- RHC**
- RZQ**

Model	A	B	C	D	d	EA	EB	FA	FB	G	GP	H	HA	HB	HG	HI	HO	HP
REAL15	7.5	9.5	5	16.6	12	6	13	3	6	6.5	65	40	6.5	4	16	14	38	39
REAL20	9.5	9.5	5	21.6	16	—	—	—	—	8.5	80	46	9	10	18	16	44	45
REAL25	9.5	11	6.5	26.4	16	8	14	4	7	8.5	90	54	9	18	23	21	52	53
REAL32	10.5	14	8	33.6	20	8	16	5	7	9.5	110	66	12	26.5	26.5	24.5	64	64
REAL40	11.5	14	8	41.6	25	10	20	5	10	10.5	130	78	12	35	30.5	28.5	76	74

Model	HS	HT	J	JK	L	LD	M	MM	N	NN	P			PA *
											Nil	TN	TF	
REAL15	25	21	M6 x 1.0	9.5	75	5.6	8	M5 x 0.8	7.5	M8 x 1.0	M5 x 0.8	—	—	45
REAL20	31	10	M6 x 1.0	10	86	5.6	10	M6 x 1.0	10	M10 x 1.0	Rc 1/8	NPT 1/8	G 1/8	50
REAL25	39	10	M8 x 1.25	10	86	7	10	M6 x 1.0	11	M14 x 1.5	Rc 1/8	NPT 1/8	G 1/8	60
REAL32	47.5	17	M10 x 1.5	15	100	9.2	12	M8 x 1.25	11.5	M20 x 1.5	Rc 1/8	NPT 1/8	G 1/8	70
REAL40	56	14	M10 x 1.5	15	136	9.2	12	M8 x 1.25	10.5	M20 x 1.5	Rc 1/4	NPT 1/4	G 1/4	90

\* PA dimensions are for split from center.

Model	PB	PW	Q	QW	RW	S	T	TT	ta	tb	W	Z
REAL15	70	95	90	30	15	77	12.5	22.5	0.5	1.0	92	112
REAL20	90	120	105	40	28	88	16.5	25.5	—	—	117	130
REAL25	100	130	105	50	22	88	16.5	25.5	0.5	1.0	127	130
REAL32	120	160	121	60	33	102	18.5	28.5	0.5	1.0	157	149
REAL40	140	190	159	84	35	138	20.5	35.5	1.0	1.0	187	194

- D-□**
- X□**

# REAL Series Auto Switch Mounting

## Auto Switch Proper Mounting Position (Detection at Stroke End)

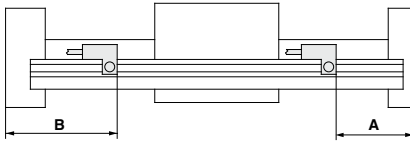

(mm)

Auto switch model  Bore size (mm)	A dimension			B dimension		
	D-A73/A80	D-A72 D-A7□H/A80H D-A73C/A80C D-F7□/J79 D-F7□W/J79W D-J79C D-F7□V/F7□WV D-F7BA D-F79F	D-F7NT	D-A73/A80	D-A72 D-A7□H/A80H D-A73C/A80C D-F7□/J79 D-F7□W/J79W D-J79C D-F7□V/F7□WV D-F7BA D-F79F	D-F7NT
10	58	58.5	63.5	45	44.5	39.5
15	65	65.5	70.5	47	46.5	41.5
20	76	76.5	81.5	54	53.5	48.5
25	76	76.5	81.5	54	53.5	48.5
32	92	92.5	97.5	57	56.5	51.5
40	130	130.5	135.5	64	63.5	58.5

Note) Adjust the auto switch after confirming the operating conditions in the actual setting.

## Operating Range

(mm)

Auto switch model	Bore size (mm)					
	10	15	20	25	32	40
D-A7□, A8□	6	6	6	6	6	6
D-F7□, J7□, F79F	3	4	3	3	3	3.5

\* Since this is a guideline including hysteresis, not meant to be guaranteed. (assuming approximately ±30% dispersion)

There may be the case it will vary substantially depending on an ambient environment.

Other than the models listed in "How to Order", the following auto switches are applicable. For detailed specifications, refer to pages 941 to 1067.

Auto switch type	Model	Electrical entry (Fetching direction)	Features
Solid state	D-F7NT	Grommet (In-line)	With timer

\* For solid state auto switches, auto switches with a pre-wired connector are also available. Refer to pages 1014 and 1015 for details.



# REAL Series Specific Product Precautions

Be sure to read this before handling the products. Refer to back page 50 for Safety Instructions and pages 3 to 12 for Actuator and Auto Switch Precautions.

## Operation

### Warning

- 1. Be aware of the space between the plates and the slide block.**  
Take sufficient care to avoid getting your hands or fingers caught when the cylinder is operated.
- 2. Do not apply a load to a cylinder which is greater than the allowable value stated in the "Model Selection" pages.**  
It may cause malfunction.
- 3. Consult with SMC when the cylinder is operated in an environment in which the cylinder is exposed to cutting fluid or water, or the cylinder sliding part lubrication deteriorates.**
- 4. When applying grease to the cylinder, use the grease already used for the product. Contact SMC, grease packs are available.**

## Mounting

### Caution

- 1. Avoid operation with the external slider fixed to the mounting surface.**  
The cylinder should be operated with the plates fixed to the mounting surface.
- 2. Make sure that the cylinder mounting surface has a flatness of 0.2 mm or less.**

If the flatness of a workpiece is not appropriate, it may adversely affect the operation since two guide shafts will be twisted. Furthermore, the increase of the sliding resistance and early abrasion of bearings may shorten the service life.

The cylinder mounting surface must have a flatness of 0.2 mm or less, and the cylinder must be mounted so as to be smoothly operated with a minimum operating pressure (0.18 MPa or less) for a full stroke.

## Disassembly and Maintenance

### Warning

- 1. Use caution, the attractive force of the magnets is very strong.**  
When removing the external slider and piston slider from the cylinder tube for maintenance, etc., handle with caution since the magnet installed in each slider has a very strong attractive force.

### Caution

- 1. Use caution when taking off the external slider, since the piston slider will be directly attracted to it.**  
When removing the external slider or piston slider from the cylinder tube, first force the sliders out of their magnetically coupled positions, and then remove them individually when there is no longer any holding force. If they are removed while still magnetically coupled, they will be directly attracted to one another and will not come apart.
- 2. Do not disassemble the magnetic components (piston and external sliders).**  
This may cause a loss of holding force and malfunction.

REA

REB

REC

Smooth

Low  
Speed

MQ

RHC

RZQ

D-□

-X□



# Linear Guide Type Single Axis/Double Axes

## *REAH/REAHT Series*

Single Axis:  $\varnothing 10$ ,  $\varnothing 15$ ,  $\varnothing 20$ ,  $\varnothing 25$

Double Axes:  $\varnothing 25$ ,  $\varnothing 32$



REA

REB

REC

Smooth

Low  
Speed

MQ

RHC

RZQ

D-□

-X□

# REAH Series Model Selection

**Pv:** Maximum operating pressure for vertical operation (MPa)  
**Wv:** Allowable load mass for vertical operation (kg)  
**α:** Load factor

$$\Sigma\alpha = \frac{\text{Load mass (W)}}{\text{Max. load mass (Wmax)}} + \frac{\text{Static moment (M)}}{\text{Allowable static moment (Mmax)}} + \frac{\text{Dynamic moment (Me)}}{\text{Allowable dynamic moment (Memax)}}$$

**Operating Conditions**

- W: Load mass (kg)
- P: Operating pressure (MPa)
- Position of workpiece center of gravity (m)
- Mode of operation (horizontal, inclined, vertical)
- U: Maximum speed (mm/s)
- Stroke (mm)

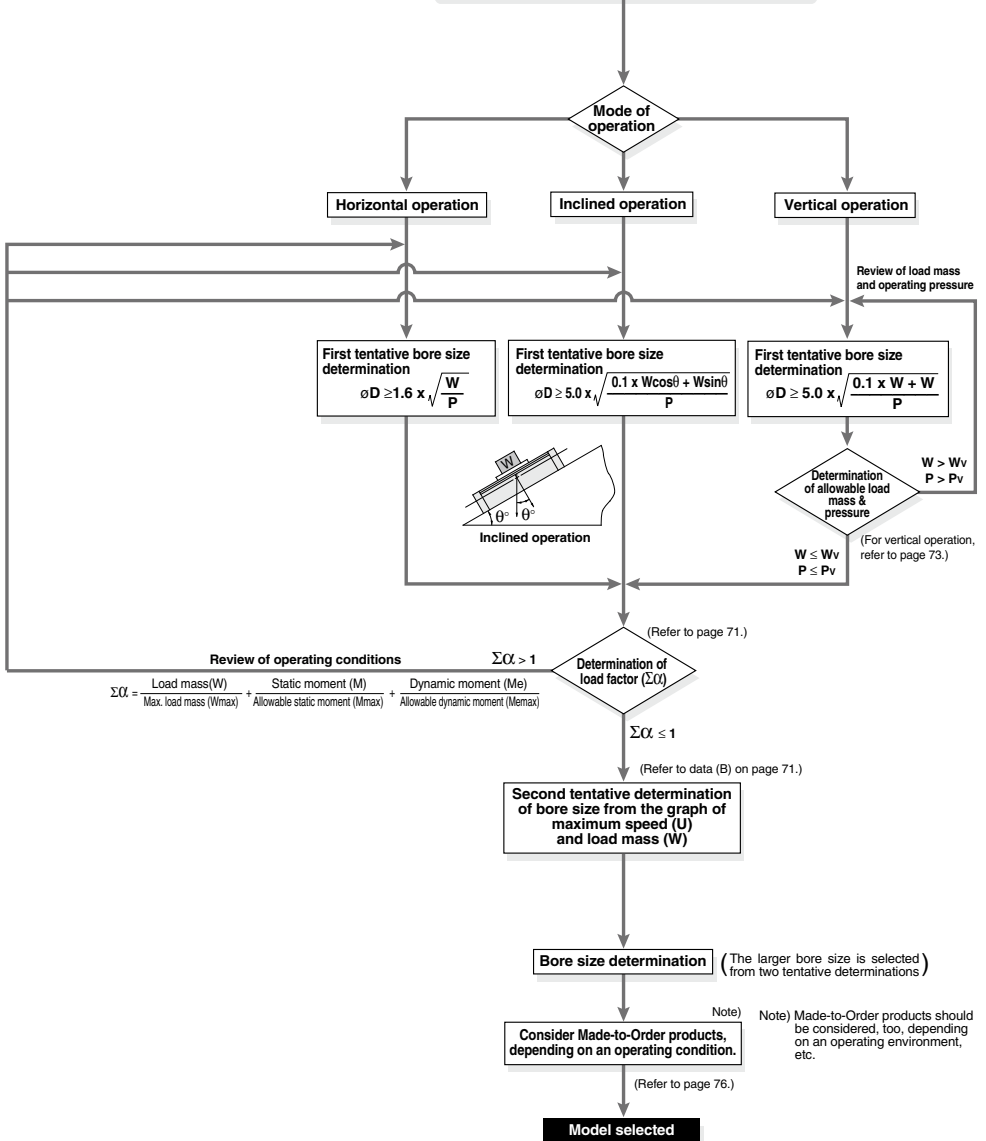



**Caution on Design 1**

The load mass allowable moment differs depending on the workpiece mounting method, cylinder mounting orientation and piston speed. In making a determination of usability, do not allow the sum ( $\sum \alpha n$ ) of the load factors ( $\alpha n$ ) for each mass and moment to exceed "1".

$$\sum \alpha n = \frac{\text{Load mass (W)}}{\text{Maximum load mass (Wmax)}} + \frac{\text{Static moment (M)}}{\text{Allowable static moment (Mmax)}} + \frac{\text{Dynamic moment (Me)}}{\text{Allowable dynamic moment (Memax)}} \leq 1$$

**Load Mass**

Maximum Load Mass (kg)

Model	W <sub>max</sub>
REAH10	4
REAH15	9
REAH20	16
REAH25	25
REAH25	
REAH32	40

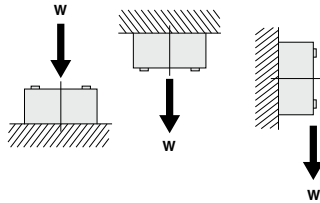

**Moment**

Allowable Moment (Static moment/Dynamic moment) (N·m)

Model	M			Model	Me		
	M1	M2	M3		M1	M2	M3
REAH10	1.5	2.5	1.5	REAH25	28	26	28
REAH15	10	16	10	REAH25	56	85	56
REAH20	13	16	13	REAH32	64	96	64

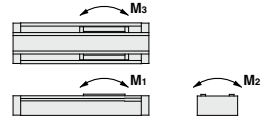

**Static Moment**

Moment generated by the workpiece mass even when the cylinder is stopped

■ Pitch moment  
M<sub>1</sub> = W·L

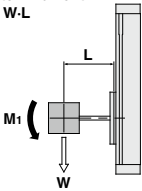

■ Roll moment  
M<sub>2</sub> = W·L

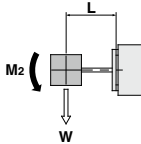

■ Yaw moment  
M<sub>3</sub> = W·(L - A)

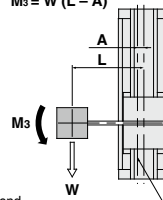

(mm)

Model	A
REAH10	15
REAH15	17.5
REAH20	19.5
REAH25	23.5
REAH25	0 <sup>+</sup>
REAH32	0 <sup>+</sup>

\* Since there are 2 guides, the guide's central axis and the cylinder's central axis are the same.

**Dynamic Moment**

Moment generated by the load equivalent to impact at the stroke end

W<sub>e</sub> = 5 × 10<sup>-3</sup> · W · g · U

- W<sub>e</sub>: Load equivalent to impact [N]
- W: Load mass [kg]
- U: Maximum speed [mm/s]
- g: Gravitational acceleration (≒ 9.8 m/s<sup>2</sup>)

■ Pitch moment  
Me<sub>1</sub> = 1/3 · W<sub>e</sub> · L

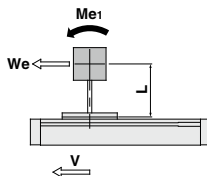

■ Yaw moment  
Me<sub>3</sub> = 1/3 · W<sub>e</sub> · (L - A)

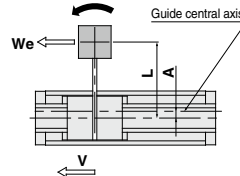

(mm)

Model	A
REAH10	15
REAH15	17.5
REAH20	19.5
REAH25	23.5
REAH25	0 <sup>+</sup>
REAH32	0 <sup>+</sup>

\* Since there are 2 guides, the guide's central axis and the cylinder's central axis are the same.

<Data (B): Maximum Speed—Load Mass Chart>

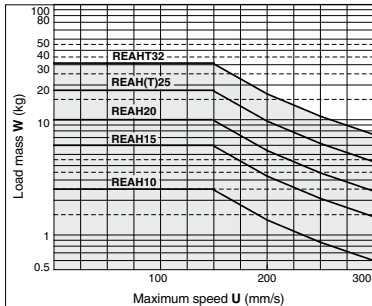

REA  
REB  
REC  
Smooth  
Low Speed  
MQ  
RHC  
RZQ

D-□  
-X□

# REAH Series

## Selection Calculation

The selection calculation finds the load factors ( $\alpha_n$ ) of the items below, where the total ( $\sum\alpha_n$ ) does not exceed 1.

$$\sum\alpha_n = \alpha_1 + \alpha_2 + \alpha_3 \leq 1$$

Item	Load factor $\alpha_n$	Note
1. Max. load mass	$\alpha_1 = W/W_{max}$	Review W. W <sub>max</sub> is the maximum load mass.
2. Static moment	$\alpha_2 = M/M_{max}$	Review M <sub>1</sub> , M <sub>2</sub> , M <sub>3</sub> . M <sub>max</sub> is the allowable moment.
3. Dynamic moment	$\alpha_3 = Me/M_{max}$	Review Me <sub>1</sub> , Me <sub>3</sub> . Me <sub>max</sub> is the allowable moment.

U: Maximum speed

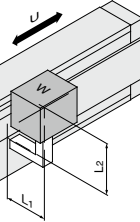

## Calculation Example

### Operating Conditions

Cylinder: REAH15  
 Mounting: Horizontal wall mounting type  
 Maximum speed: U = 300 [mm/s]  
 Load mass: W = 1 [kg] (Except mass of arm section)  
 L<sub>1</sub> = 200 [mm]  
 L<sub>2</sub> = 200 [mm]

Item	Load factor $\alpha_n$	Note
<b>1. Maximum load mass</b> 	$\alpha_1 = W/W_{max}$ $= 1/9$ $= 0.111$	Examine W.
<b>2. Static moment</b> 	$M_2 = W \cdot L_1$ $= 10 \cdot 0.2$ $= 2 \text{ [N-m]}$ $\alpha_2 = M_2/M_{2max}$ $= 2/16$ $= 0.125$	$W = 1 \text{ [kg]}$ $= 10 \text{ [N]}$ Examine M <sub>2</sub> . Since M <sub>1</sub> & M <sub>3</sub> are not generated, investigation is unnecessary.
<b>3. Dynamic moment</b> 	$W_e = 5 \times 10^{-3} \cdot W \cdot g \cdot U$ $= 5 \times 10^{-3} \cdot 1 \cdot 9.8 \cdot 300$ $= 15 \text{ [N]}$ $Me_3 = 1/3 \cdot W_e \cdot (L_2 - A)$ $= 1/3 \cdot 15 \cdot 0.182$ $= 0.91 \text{ [N-m]}$ $\alpha_3 = Me_3/Me_{3max}$ $= 0.91/10$ $= 0.091$	Examine Me <sub>3</sub> .
	$Me_1 = 1/3 \cdot W_e \cdot L_1$ $= 1/3 \cdot 15 \cdot 0.2$ $= 1 \text{ [N-m]}$ $\alpha_4 = Me_1/Me_{1max}$ $= 1/10$ $= 0.1$	Examine Me <sub>1</sub> .

$$\begin{aligned} \sum\alpha_n &= \alpha_1 + \alpha_2 + \alpha_3 + \alpha_4 \\ &= 0.111 + 0.125 + 0.091 + 0.10 \\ &= 0.427 \end{aligned}$$

Can be used base on  $\sum\alpha_n = 0.427 \leq 1$

**Caution on Design 2**

**Table Deflection Amount**

**Displacement of Table due to Pitch Moment Load**

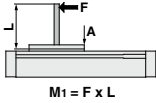

**REAH10**

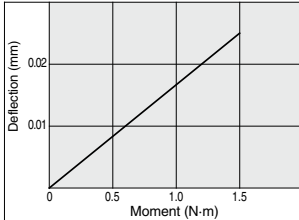

**REAH15,20,25**

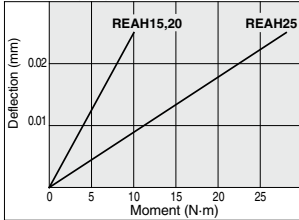

**REAH25,32**

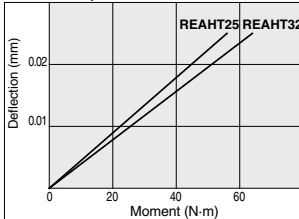

**Displacement of Table due to Roll Moment Load**

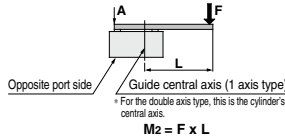

**REAH10**

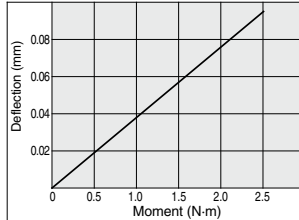

**REAH15,20,25**

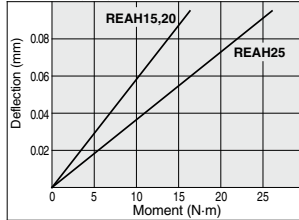

**REAH25,32**

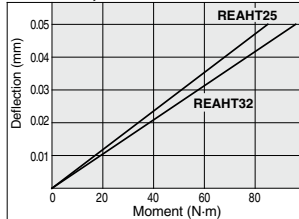

**Displacement of Table due to Yaw Moment Load**

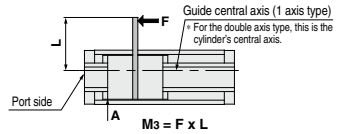

Note) Deflection: Displacement of section A when force acts on section F

**REAH10**

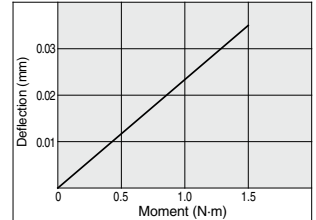

**REAH15,20,25**

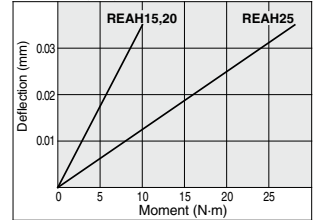

**REAH25,32**

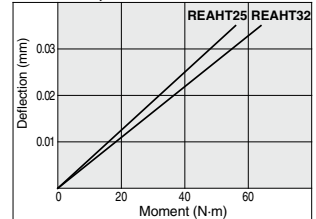

Note) Deflection when a moment other than the above is applied can be specified by extending the lines in the graphs above.

**Vertical Operation**

When using in vertical operation, prevention of workpiece dropping due to breaking of the magnetic coupling should be considered. The allowable load mass and maximum operating pressure should be as shown in the table below. When the cylinder is mounted vertically or sidelong, sliders may move downwards due to the self-weight or workpiece mass. If an accurate stopping position is required at the stroke end or the middle-stroke, use an external stopper to secure accurate positioning.

Model	Allowable load mass Wv (kg)	Maximum operating pressure Pv (MPa)
REAH10	2.7	0.55
REAH15	7.0	0.65
REAH20	11.0	0.65
REAH25	18.5	0.65
REAH25	18.5	0.65
REAH32	30.0	0.65

**Intermediate Stop**

The cushion effect (smooth start-up, soft stop) exists only before the stroke end in the stroke ranges indicated in the table below.

The cushion effect (smooth start-up, soft stop) cannot be obtained in an intermediate stop or a return from an intermediate stop using an external stopper, etc.

**Cushion Stroke**

Model	Stroke (mm)
REAH10	20
REAH15	25
REAH20	30
REAH25	30
REAH25	30
REAH32	30

REA

REB

REC

Smooth

Low Speed

MQ

RHC

RZQ

D-□

X-□

# REAH Series

## Stroke Adjustment

The adjustment bolt is adjusted to the optimum position for smooth acceleration and deceleration at the time of shipment, and should be operated at the full stroke. When stroke adjustment is necessary, the maximum amount of adjustment on one side is 2 mm. (Do not adjust more than 2 mm, as it will not be possible to obtain smooth acceleration and deceleration.)

Do not adjust based on the stopper's movement, as this can cause cylinder damage.

### Stroke adjustment method

Loosen the round head Phillips screws, and remove the top covers and dust covers (4 pcs.). Then loosen the hexagon nut, and after performing the stroke adjustment from the plate side with a hexagon wrench, retighten and secure the hexagon nut.

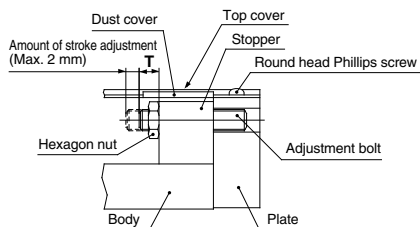

## Adjustment Bolt Position (at the time of shipment), Hexagon Nut Tightening Torque

Model	T (mm)	Tightening torque (N·m)
REAH10	7	1.67
REAH15	7	
REAH20	7	
REAH25	9	3.14
REAH25	9	
REAH32	9	

After adjusting the stroke, replace the top covers and dust covers. Tighten the round head Phillips screws for securing the top covers with a torque of 0.58 N·m.

# Sine Rodless Cylinder Linear Guide Type

# REAH Series

Single Axis:  $\varnothing 10, \varnothing 15, \varnothing 20, \varnothing 25$ /Double Axes:  $\varnothing 25, \varnothing 32$

## How to Order

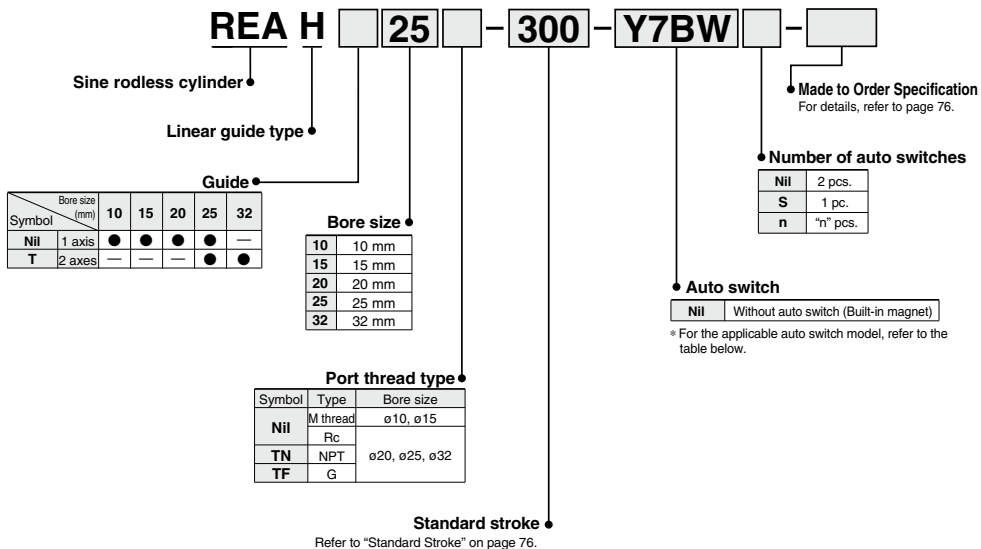

## Applicable Auto Switches

Refer to pages 941 to 1067 for further information on auto switches.

Type	Special function	Electrical entry	Indicator light	Wiring (Output)	Load voltage			Auto switch model		Lead wire length (m)*			Pre-wired connector	Applicable load	
					DC	AC		Perpendicular	In-line	0.5 (Nil)	3 (L)	5 (Z)			
										●	●	○			
Solid state auto switch	—	Grommet	Yes	3-wire (NPN)	5 V, 12 V	—	—	<b>Y69A</b>	<b>Y59A</b>	●	●	○	○	IC circuit Relay, PLC	
				3-wire (PNP)				<b>Y7PV</b>	<b>Y7P</b>	●	●	○	○		
				2-wire	12 V			<b>Y69B</b>	<b>Y59B</b>	●	●	○	○		
	3-wire (NPN)			5 V, 12 V	<b>Y7NWV</b>			<b>Y7NW</b>	●	●	○	○			
	3-wire (PNP)				<b>Y7PWV</b>			<b>Y7PW</b>	●	●	○	○			
	2-wire			12 V	<b>Y7BWW</b>			<b>Y7BW</b>	●	●	○	○			
Reed auto switch	—	Grommet	Yes	3-wire (NPN equivalent)	—	5 V	—	—	<b>Z76</b>	●	●	—	—	IC circuit	—
				2-wire	24 V	12 V	100 V	—	<b>Z73</b>	●	●	●	—	—	Relay, PLC
					5 V, 12 V	100 V or less	—	<b>Z80</b>	●	●	—	—	—	IC circuit	
					—	—	—	—	—	—	—	—	—	—	—

\*\* Water resistant type auto switches can be mounted on the above models, but in such case SMC cannot guarantee water resistance. Consult with SMC regarding water resistant types with the above model numbers.

\* Lead wire length symbols: 0.5 m.....Nil (Example) Y7BW  
3 m.....L (Example) Y7BWL  
5 m.....Z (Example) Y7BWZ

\* Solid state auto switches marked with "○" are produced upon receipt of order.

• Since there are other applicable auto switches than listed, refer to page 83 for details.  
• For details about auto switches with pre-wired connector, refer to pages 1014 and 1015.  
\* Auto switches are shipped together (not assembled).

REA

REB

REC

Smooth

Low Speed

MQ

RHC

RZQ

# REAH Series



## Symbol

Air cushion  
(Magnet type)

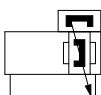

**Made to Order: Individual Specifications**  
(For details, refer to page 112.)

Symbol	Specifications
-X168	Helical insert thread specifications

## Made to Order Specifications

[Click here for details](#)

Symbol	Specifications
-XB10	Intermediate stroke (Using exclusive body)

## Specifications

Bore size (mm)	10	15	20	25	32
<b>Fluid</b>	Air				
<b>Action</b>	Double acting				
<b>Maximum operating pressure</b>	0.7 MPa				
<b>Minimum operating pressure</b>	0.2 MPa				
<b>Proof pressure</b>	1.05 MPa				
<b>Ambient and fluid temperature</b>	-10 to 60°C (No freezing)				
<b>Piston speed (Max.)</b> <sup>Note)</sup>	70 to 300 mm/s				
<b>Lubrication</b>	Not required (Non-lube)				
<b>Stroke length tolerance</b>	0 to 1.8 mm				
<b>Piping</b>	Centralized piping type				
<b>Piping port size</b>	M5 x 0.8		Rc 1/8		
<b>Holding force (N)</b>	53.9	137	231	363	588

Note) Piston speed above indicates the maximum speed. It takes approximately 0.5 seconds (for one side) after the slide block moves from the stroke end until it goes through the cushion stroke, while it takes approximately 1 second for both sides.

## Standard Stroke

Bore size (mm)	Number of axes	Standard stroke (mm)	Maximum manufacturable stroke (mm)
10	1 axis	150, 200, 300	500
15		150, 200, 300, 400, 500	750
20		200, 300, 400, 500, 600	1000
25		200, 300, 400, 500, 600, 800	1200
25	2 axes	200, 300, 400, 500, 600, 800, 1000	
32		1500	

Note 1) Stroke exceeding the standard stroke will be available upon request for special.

Note 2) Intermediate strokes other than made-to-order (refer to -XB10) are available as special.

## Weight

Model	Standard stroke (mm)								(kg)
	150	200	300	400	500	600	800	1000	
REAH10	1.2	1.3	1.6	—	—	—	—	—	—
REAH15	2.5	2.7	3.2	3.6	4.1	—	—	—	—
REAH20	—	3.5	4.0	4.4	4.9	5.4	—	—	—
REAH25	—	5.3	6.0	6.6	7.3	8.0	9.4	—	—
REAH25	—	6.2	7.3	8.3	9.4	10.4	12.5	14.6	—
REAH32	—	9.6	10.7	11.9	13.0	14.2	16.5	18.8	—

## Theoretical Output

Bore size (mm)	Piston area (mm <sup>2</sup> )	Operating pressure (MPa)						(N)
		0.2	0.3	0.4	0.5	0.6	0.7	
10	78	15	23	31	39	46	54	—
15	176	35	52	70	88	105	123	—
20	314	62	94	125	157	188	219	—
25	490	98	147	196	245	294	343	—
32	804	161	241	322	402	483	563	—

Note) Theoretical output (N) = Pressure (MPa) x Piston area (mm<sup>2</sup>)

**Construction:  $\phi 10, \phi 15$**

**Single axis type: REAH**

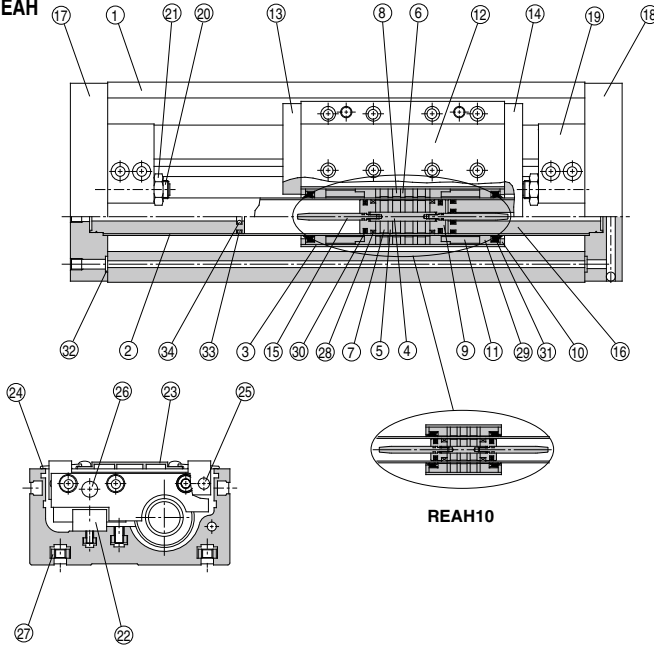

- REA**
- REB**
- REC**
- Smooth
- Low Speed
- MQ**
- RHC**
- RZQ**

**Component Parts**

No.	Description	Material	Note
1	Body	Aluminum alloy	Hard anodized
2	Cylinder tube	Stainless steel	
3	External slider tube	Aluminum alloy	
4	Shaft	Stainless steel	
5	Piston side yoke	Rolled steel plate	Zinc chromated
6	External slider side yoke	Rolled steel plate	Zinc chromated
7	Magnet A	—	
8	Magnet B	—	
9	Piston	Aluminum alloy	Chromated
10	Spacer	Rolled steel plate	Nickel plated
11	Space ring	Aluminum alloy	Chromated (Except REAH10)
12	Slide table	Aluminum alloy	Hard anodized
13	Side plate A	Aluminum alloy	Hard anodized
14	Side plate B	Aluminum alloy	Hard anodized
15	Cushion ring	Stainless steel	
16	Internal stopper	Aluminum alloy	Anodized
17	Plate A	Aluminum alloy	Hard anodized

**Component Parts**

No.	Description	Material	Note
18	Plate B	Aluminum alloy	Hard anodized
19	Stopper	Aluminum alloy	Anodized
20	Adjustment bolt	Chromium molybdenum steel	Nickel plated
21	Hexagon nut	Carbon steel	Nickel plated
22	Linear guide	—	
23	Top cover	Aluminum alloy	Hard anodized
24	Dust cover	Special resin	
25	Magnet (for auto switch)	—	
26	Parallel pin	Carbon steel	Nickel plated
27	Square nut for body mounting	Carbon steel	Nickel plated (Accessory)
28*	Wear ring A	Special resin	
29*	Wear ring B	Special resin	
30*	Piston seal	NBR	
31*	Scraper	NBR	
32*	O-ring	NBR	
33*	O-ring	NBR	
34*	Cushion seal	NBR	

**Replacement Parts: Seal Kit**

Bore size (mm)	Kit no.	Contents
10	REAH10-PS	Set of nos. above ②③ ④ ⑤ ⑥ ⑦ ⑧ ⑨ ⑩ ⑪ ⑫ ⑬ ⑭ ⑮ ⑯ ⑰ ⑱ ⑲ Note 1) Note 2)
15	REAH15-PS	Set of nos. above ②③ ④ ⑤ ⑥ ⑦ ⑧ ⑨ ⑩ ⑪ ⑫ ⑬ ⑭ ⑮ ⑯ ⑰ ⑱ ⑲ Note 1)

Note 1) It may be difficult to replace the cushion seal ⑳.  
 Note 2) For replacement of wear ring A ⑳ of  $\phi 10$ , please consult with SMC.  
 \* Seal kit includes a grease pack ( $\phi 10$ : 5 g and 10 g,  $\phi 15$ : 10 g).  
 Order with the following part number when only the grease pack is needed.  
**For  $\phi 10$  grease pack part no.: GR-F-005 (5 g) For external sliding part**  
**GR-S-010 (10 g) For tube interior**  
**For  $\phi 15$  grease pack part no.: GR-S-010 (10 g)**

Note 1) Seal kit includes ⑳ to ㉔. Order the seal kit, based on each bore size.  
 Note 2) Square nut for body mounting ㉔: 4 pieces

- D
- X

# REAH Series

**Construction:  $\varnothing 20, \varnothing 25$**

**Single axis type: REAH**

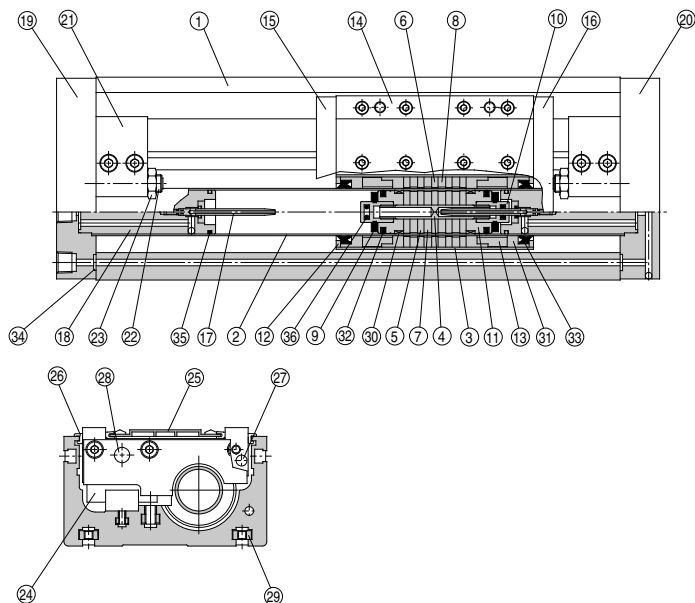

## Component Parts

No.	Description	Material	Note
1	Body	Aluminum alloy	Hard anodized
2	Cylinder tube	Stainless steel	
3	External slider tube	Aluminum alloy	
4	Shaft	Stainless steel	
5	Piston side yoke	Rolled steel plate	Zinc chromated
6	External slider side yoke	Rolled steel plate	Zinc chromated
7	Magnet A	—	
8	Magnet B	—	
9	Bumper	Urethane rubber	
10	Cushion seal holder	Aluminum alloy	Chromated
11	Piston	Aluminum alloy	Chromated
12	Spacer	Rolled steel plate	Nickel plated
13	Space ring	Aluminum alloy	Chromated
14	Slide table	Aluminum alloy	Hard anodized
15	Side plate A	Aluminum alloy	Hard anodized
16	Side plate B	Aluminum alloy	Hard anodized
17	Cushion ring	Stainless steel	
18	Internal stopper	Aluminum alloy	Anodized

## Component Parts

No.	Description	Material	Note
19	Plate A	Aluminum alloy	Hard anodized
20	Plate B	Aluminum alloy	Hard anodized
21	Stopper	Aluminum alloy	Anodized
22	Adjustment bolt	Chromium molybdenum steel	Nickel plated
23	Hexagon nut	Carbon steel	Nickel plated
24	Linear guide		
25	Top cover	Aluminum alloy	Hard anodized
26	Dust cover	Special resin	
27	Magnet (for auto switch)	—	
28	Parallel pin	Carbon steel	Nickel plated
29	Square nut for body mounting	Carbon steel	Nickel plated (Accessory)
30*	Wear ring A	Special resin	
31*	Wear ring B	Special resin	
32*	Piston seal	NBR	
33*	Scraper	NBR	
34*	O-ring	NBR	
35*	O-ring	NBR	
36*	Cushion seal	NBR	

Note 1) Seal kit includes ⑩ to ⑳. Order the seal kit, based on each bore size.  
 Note 2) Square nut for body mounting ⑳: 4 pieces

## Replacement Parts: Seal Kit

Bore size (mm)	Kit no.	Contents
20	REAH20-PS	Set of nos. above
25	REAH25-PS	⑩ ⑪ ⑫ ⑬ ⑭ ⑮ ⑯ ⑰ ⑱ ⑳

Note) It may be difficult to replace the cushion seal ⑳.

\* Seal kit includes a grease pack (10 g).

Order with the following part number when only the grease pack is needed.

**Grease pack part no.: GR-S-010 (10 g)**



**Construction:  $\varnothing 25, \varnothing 32$**

**Double axis type: REAHT**

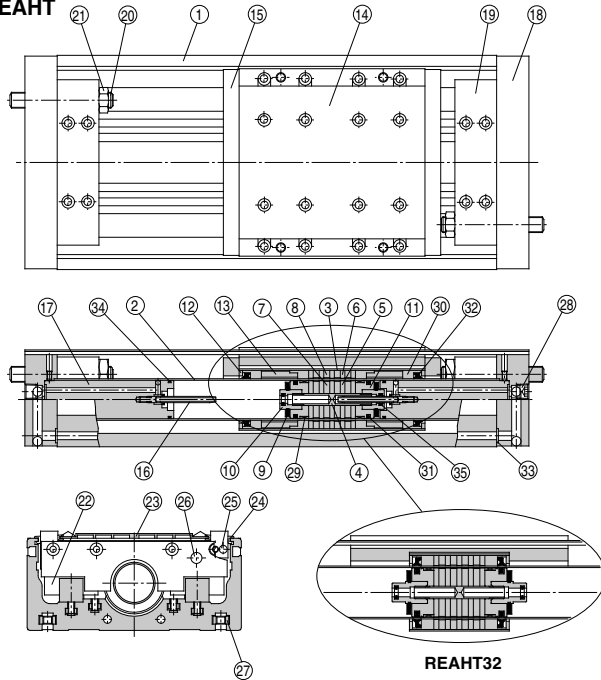

REAHT32

**Component Parts**

No.	Description	Material	Note
1	Body	Aluminum alloy	Hard anodized
2	Cylinder tube	Stainless steel	
3	External slider tube	Aluminum alloy	
4	Shaft	Stainless steel	
5	Piston side yoke	Rolled steel plate	Zinc chromated
6	External slider side yoke	Rolled steel plate	Zinc chromated
7	Magnet A	—	
8	Magnet B	—	
9	Bumper	Urethane rubber	
10	Cushion seal holder	Aluminum alloy	Chromated
11	Piston	Aluminum alloy	Chromated
12	Spacer	Rolled steel plate	Nickel plated
13	Space ring	Aluminum alloy	Chromated (Except REAHT32)
14	Slide table	Aluminum alloy	Hard anodized
15	Side plate	Aluminum alloy	Hard anodized (Except REAHT32)
16	Cushion ring	Brass	Electroless nickel plated (REAHT32)
		Stainless steel	REAHT25
17	Internal stopper	Aluminum alloy	Anodized

**Component Parts**

No.	Description	Material	Note
18	Plate	Aluminum alloy	Hard anodized
19	Stopper	Aluminum alloy	Anodized
20	Adjustment bolt	Chromium molybdenum steel	Nickel plated
21	Hexagon nut	Carbon steel	Nickel plated
22	Linear guide		
23	Top cover	Aluminum alloy	Hard anodized
24	Dust cover	Special resin	
25	Magnet (for auto switch)	—	
26	Parallel pin	Carbon steel	Nickel plated
27	Square nut for body mounting	Carbon steel	Nickel plated (Accessory)
28	Hexagon socket head taper plug	Carbon steel	Nickel plated
29*	Wear ring A	Special resin	
30*	Wear ring B	Special resin	
31*	Piston seal	NBR	
32*	Scraper	NBR	
33*	O-ring	NBR	
34*	O-ring	NBR	
35*	Cushion seal	NBR	

Note 1) Seal kit includes 29 to 35. Order the seal kit, based on each bore size.  
Note 2) Square nut for body mounting 27: 4 pieces

**Replacement Parts: Seal Kit**

Bore size (mm)	Kit no.	Contents
25	REAHT25-PS	Set of nos. above 29, 30, 31, 32, 33, 34, 35
32	REAHT32-PS	

Note) It may be difficult to replace the cushion seal 35.  
\* Seal kit includes a grease pack (10 g).  
Order with the following part number when only the grease pack is needed.  
Grease pack part no.: GR-S-010 (10 g)

- REA
- REB
- REC
- Smooth
- Low Speed
- MQ
- RHC
- RZQ

- D-□
- X□



Dimensions:  $\varnothing 15$ ,  $\varnothing 20$ ,  $\varnothing 25$

Single axis type: REAH

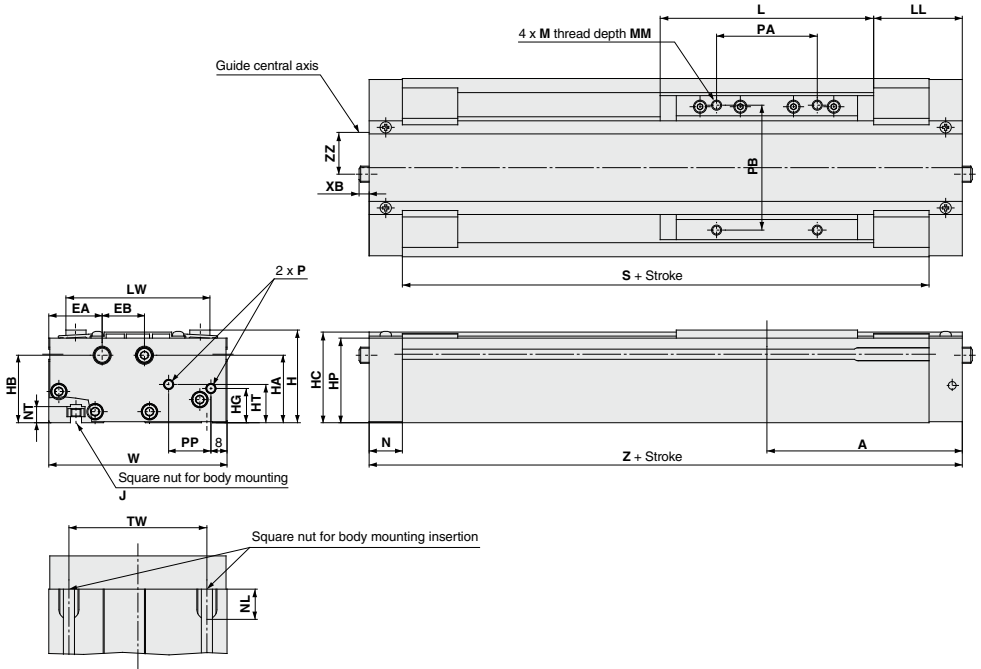

- REAH
- REB
- REC
- Smooth
- Low Speed
- MQ
- RHC
- RZQ

Model	A	EA	EB	H	HA	HB	HC	HG	HP	HT	J	L	LL	LW	M	MM
REAH15	97	26.5	21	46	33.5	33.5	45	17	42	19	M5 x 0.8	106	44	71.5	M5 x 0.8	8
REAH20	102.5	26.5	22	54	42.5	41.5	53	16	50	23.5	M5 x 0.8	108	48.5	75.5	M5 x 0.8	8
REAH25	125	29	24	63	46	46	61.5	25	58.5	28	M6 x 1.0	138	56	86	M6 x 1.0	10

Model	N	NL	NT	P			PA	PB	PP	S	TW	W	XB	Z	ZZ
				Nil	TN	TF									
REAH15	16.5	15	8	M5 x 0.8	—	—	50	62	21	161	65	88.5	—	194	17.5
REAH20	18	15	8	Rc 1/8	NPT 1/8	G 1/8	50	65	23	169	70	92.5	—	205	19.5
REAH25	20.5	18	9	Rc 1/8	NPT 1/8	G 1/8	65	75	27	209	75	103	9.5	250	23.5

- D-□
- X□

# REAH Series

Dimensions:  $\varnothing 25$ ,  $\varnothing 32$

## Double axis type: REAHT

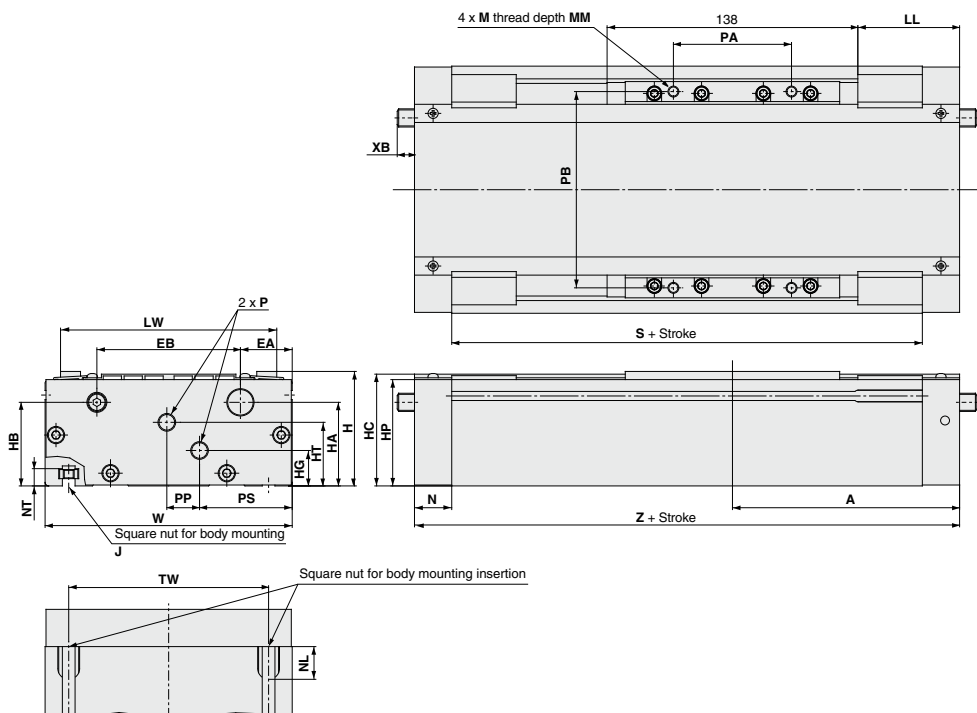

Model	A	EA	EB	H	HA	HB	HC	HG	HP	HT	J	LL	LW	M	MM	N
REAHT25	125	28.5	79	63	46	46	61.5	19.5	58.5	35	M6 x 1.0	56	119	M6 x 1.0	10	20.5
REAHT32	132.5	30	90	75	52.5	57.5	72.5	25	69.5	43	M8 x 1.25	63.5	130	M8 x 1.25	12	23

Model	NL	NT	P			PA	PB	PP	PS	S	TW	W	XB	Z
			NII	TN	TF									
REAHT25	18	9	Rc 1/8	NPT 1/8	G 1/8	65	108	18	51	209	110	136	9.5	250
REAHT32	22.5	12	Rc 1/8	NPT 1/8	G 1/8	66	115	14	61	219	124	150	2	265





# REAH Series

## Specific Product Precautions

Be sure to read this before handling the products. Refer to back page 50 for Safety Instructions and pages 3 to 12 for Actuator and Auto Switch Precautions.

### Mounting

#### ⚠ Caution

1. The interior is protected to a certain extent by the top cover, however, when performing maintenance, etc., take care not to cause scratches or other damage to the cylinder tube, slide table or linear guide by striking them or placing objects on them.  
Cylinder bores are manufactured to precise tolerances, so that even a slight deformation may cause faulty operation.
2. Because the slider is supported by precision bearings, take care not to apply strong impacts or excessive moments to the table when loading a workpiece.
3. Mounting of the cylinder body  
The body is mounted using the square nuts, which are included, in the two T-slots on the bottom of the body. Refer to the table below for mounting bolt dimensions and tightening torque.

Model	REAH10	REAH15	REAH20	REAH25	REAH25	REAH32
Bolt dimensions	Thread size M4 x 0.7	M5 x 0.8	M6 x 1.0	M6 x 1.0	M8 x 1.25	M8 x 1.25
Dimension t	L-7	L-8	L-9	L-9	L-12	L-12
Tightening torque	N·m	1.37	2.65	4.4	13.2	13.2

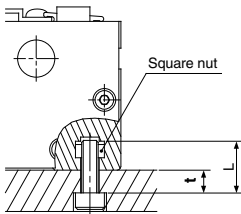

### Operation

#### ⚠ Caution

1. The unit can be used with a direct load within the allowable range, but when connecting to a load which has an external guide mechanism, careful alignment is necessary.  
Since variation of the shaft center increases as the stroke becomes longer, a connection method should be devised which allows for this displacement.
2. Since the guide is adjusted at the time of shipment, unintentional movement of the adjustment setting should be avoided.
3. Please contact SMC before operating in an environment where there will be contact with cutting chips, dust (paper debris, lint, etc.) or cutting oil (gas oil, water, warm water, etc.).
4. Do not operate with the magnetic coupling out of position.  
In case the magnetic coupling is out of position, push the external slider back into the correct position by hand at the end of the stroke (or correct the piston slider with air pressure).