

New Release

High Rigidity Slider Type Electric Actuator



[Excludes the motorless type]

● Supports **750 W** (Motor output)

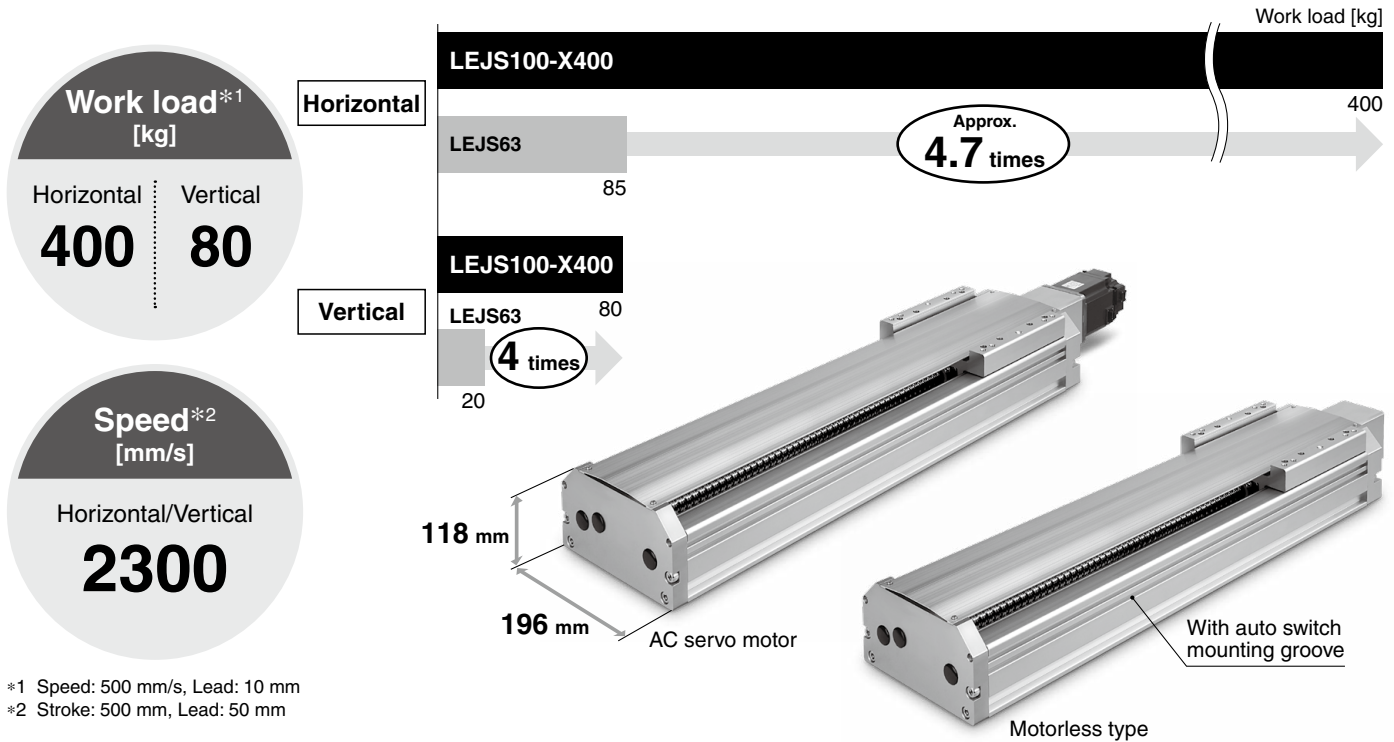

*1 Speed: 500 mm/s, Lead: 10 mm
*2 Stroke: 500 mm, Lead: 50 mm

● Max. acceleration/deceleration: **9800 mm/s²**

AC Servo Motor Absolute Type

Pulse input type/Positioning type LECSB-T Series

- Positioning by up to 255 point tables
- Input type: Pulse input (Sink (NPN) type interface/Source (PNP) type interface)
- Control encoder: Absolute 22-bit encoder (Resolution: 4194304 p/rev)
- STO (Safe Torque Off) safety function available
- Parallel input: 10 inputs
output: 6 outputs



Motorless Type Compatible Motors by Manufacturer

Manufacturer	Series	Type	Compatible interfaces						
			Battery-less absolute encoder	Pulse input	CC-Link IE \mathbb{E} field	CC-Link IE TSN	SSCNET III/H	MECHATROLINK II	MECHATROLINK III
Mitsubishi Electric Corporation	MELSERVO-J4	HG-KR73	●	●	●	●	●	●	●
	MELSERVO-J5	HK-KT7M3W	●	●	●	●	●	●	●
YASKAWA Electric Corporation	Σ -V	SGMJV-08	●	●	●	●	●	●	●
	Σ -7	SGM7J-08	●	●	●	●	●	●	●

Trademark: DeviceNet™ is a trademark of ODVA.

LEJS100-X400



LEJS100-X400

AC Servo Motor Motorless Type

System Construction

Absolute encoder compatible **LECSB-T Series** (Pulse input type/Positioning type)

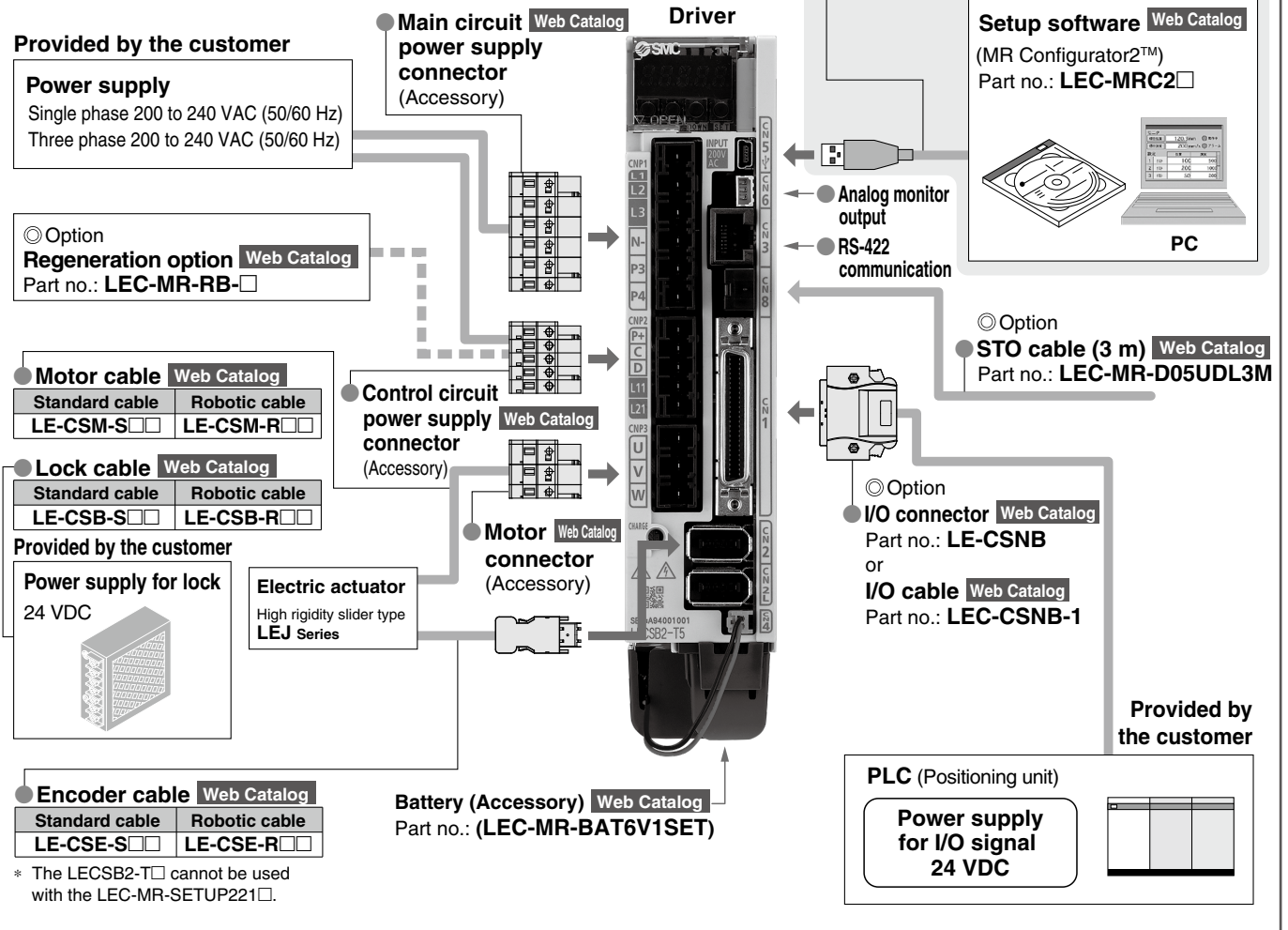

Electric Actuator/High Rigidity Slider Type Ball Screw Drive/LEJS100-X400 Model Selection



Speed-Work Load Graph/Required Conditions for "Regeneration Option" (Guide)

AC Servo Motor

Horizontal

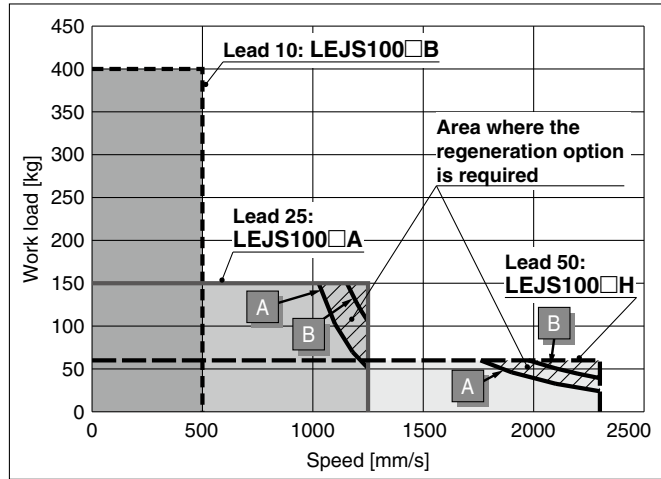

Vertical

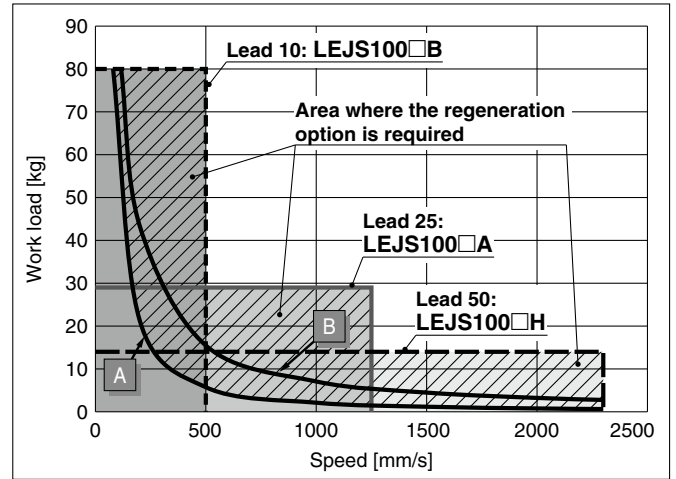

Required conditions for "Regeneration option"

* The regeneration option is required when using the product within the "area where the regeneration option is required" in the graph.
(Order separately.)

"Regeneration Option" Models

Operating condition	Regenerative condition	Regeneration option
A	Duty ratio 100%	LEC-MR-RB-032
B		LEC-MR-RB-12

Speed-Work Load Graph (Guide)

Motorless Type

Horizontal

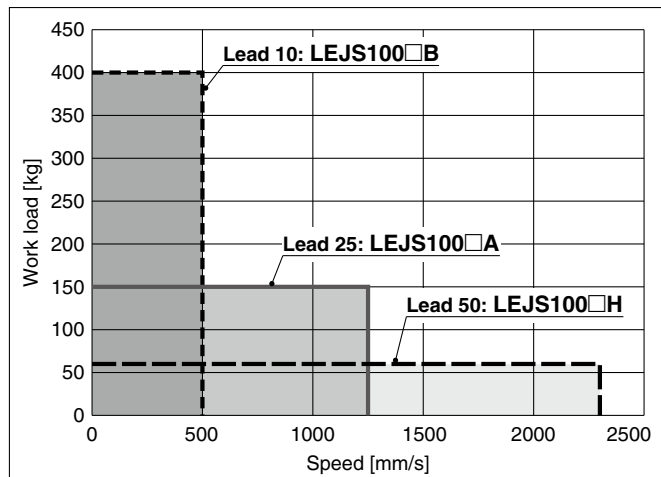

Vertical

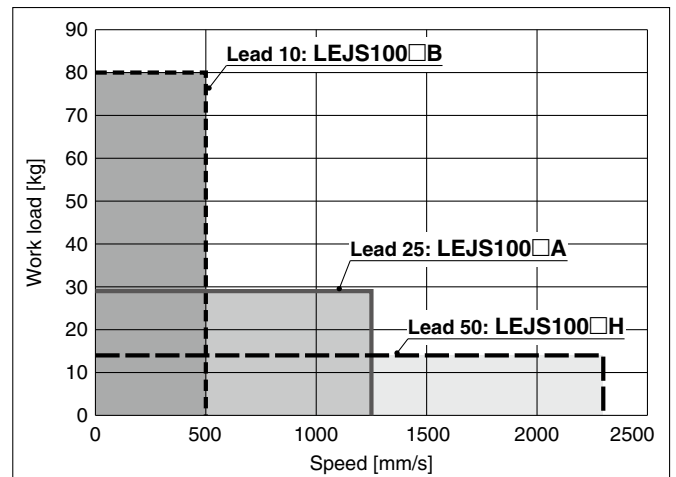







LEJS100-X400

AC Servo Motor Motorless Type

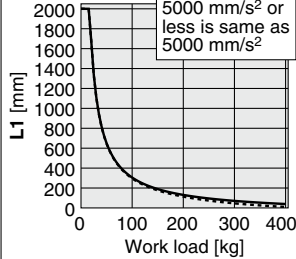
* This graph shows the amount of allowable overhang (guide unit) when the center of gravity of the workpiece overhangs in one direction. When selecting the overhang, refer to "Calculation of Guide Load Factor" for confirmation.

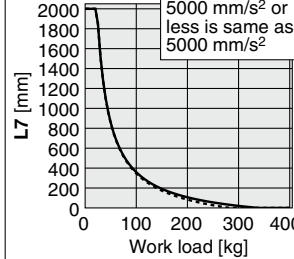
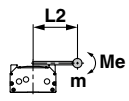
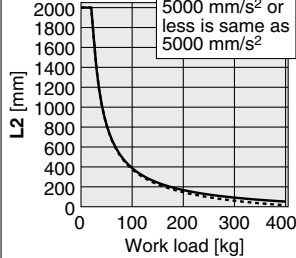
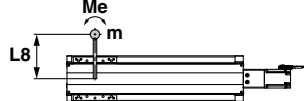
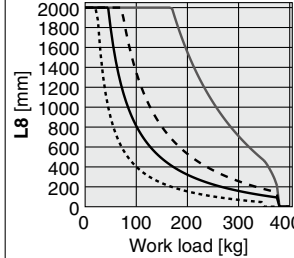
Dynamic Allowable Moment

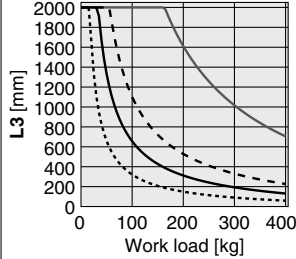
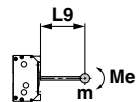
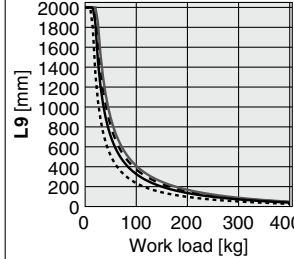
Acceleration/Deceleration ——— 1000 mm/s² - - - - 3000 mm/s² ——— 5000 mm/s² ······ 9800 mm/s²

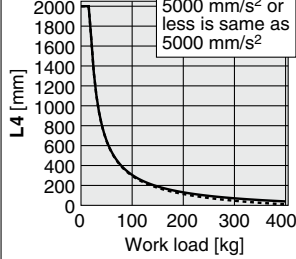
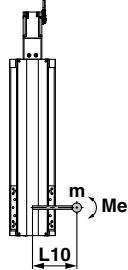
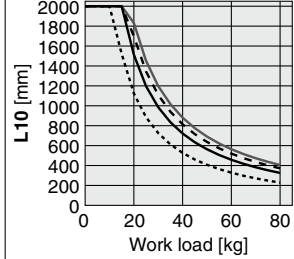
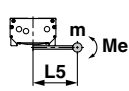
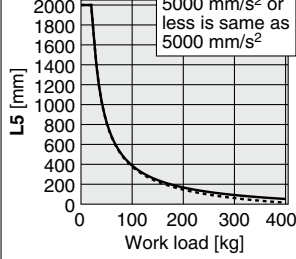
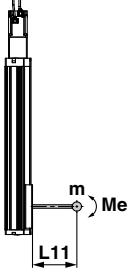
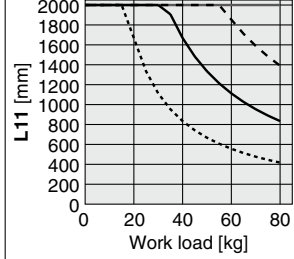
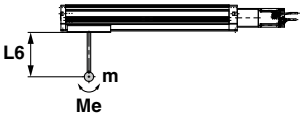
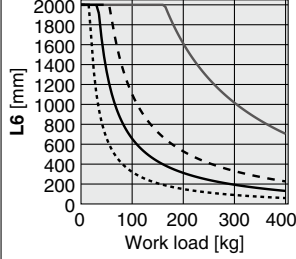
Orientation		Load overhanging direction	Orientation	Load overhanging direction	
		m: Work load [kg] Me: Dynamic allowable moment [N·m] L: Overhang to the work load center of gravity [mm]			
Horizontal	X	 	Wall	X	 
	Y	 		Y	 
	Z	 		Z	 
Bottom	X	 	Vertical	Y	 
	Y	 		Z	 
	Z	 			

Calculation of Guide Load Factor

1. Decide operating conditions.

Model: LEJS-X400

Size: 100

Mounting orientation: Horizontal/Bottom/Wall/Vertical

Acceleration [mm/s²]: **a**

Work load [kg]: **m**

Work load center position [mm]: **Xc/Yc/Zc**

2. Select the target graph with reference to the model, size, and mounting orientation.

3. Based on the acceleration and work load, obtain the overhang [mm]: **Lx/Ly/Lz** from the graph.

4. Calculate the load factor for each direction.

$$\alpha_x = Xc/Lx \quad \alpha_y = Yc/Ly \quad \alpha_z = Zc/Lz$$

5. Confirm the total of α_x , α_y , and α_z is 1 or less.

$$\alpha_x + \alpha_y + \alpha_z \leq 1$$

When 1 is exceeded, please consider a reduction of acceleration and work load, or a change of the work load center position and series.

Example

1. Operating conditions

Model: LEJS-X400

Size: 100

Mounting orientation: Horizontal

Acceleration [mm/s²]: 5000

Work load [kg]: 100

Work load center position [mm]: **Xc = 50, Yc = 100, Zc = 200**

2. Select the graph on page 3, top and left side first row.

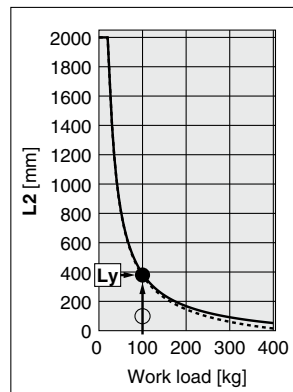
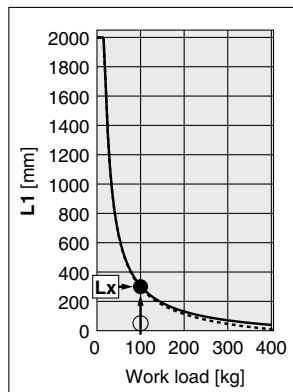

3. **Lx = 300 mm, Ly = 380 mm, Lz = 650 mm**

4. The load factor for each direction can be obtained as follows.

$$\alpha_x = 50/300 = 0.17$$

$$\alpha_y = 100/380 = 0.26$$

$$\alpha_z = 200/650 = 0.31$$

5. $\alpha_x + \alpha_y + \alpha_z = 0.74 \leq 1$

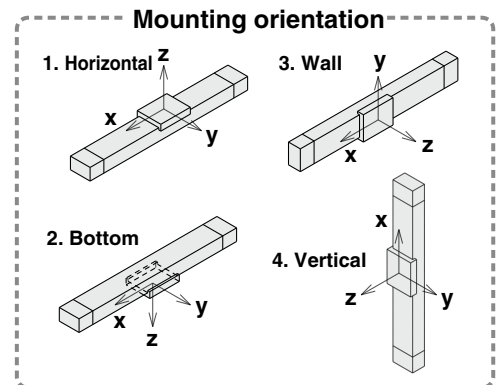
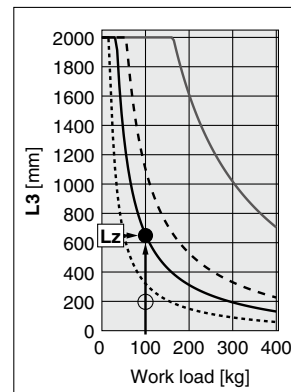

Electric Actuator/High Rigidity Slider Type Ball Screw Drive

LEJS100-X400



How to Order

LEJS100 T9 **B** - **500** **T** - **□** **□** **□** **□** - X400

Motor capacity: 750 W

With top cover type

1 Lead [mm]

H	50
A	25
B	10

2 Stroke [mm]

500	500
1000	1000
1500	1500

3 Motor option

Nil	Without option
B	With lock

4 Cable type*1*2

Nil	Without cable
S	Standard cable
R	Robotic cable (Flexible cable)

*1 When a driver type is selected, a cable is included. Select the cable type and cable length.
Example

S2S2: Standard cable (2 m) + Driver (LECSS2)
S2 : Standard cable (2 m)
Nil : Without cable and driver

*2 The motor and encoder cables are included. (The lock cable is included when the motor with lock option is selected.)

5 Cable length [m]*3

Nil	Without cable
2	2
5	5
A	10

*3 When "Without driver" is selected for driver type, only "Nil: Without cable" can be selected.

6 Driver type*1

	Compatible driver Model	Power supply voltage [V]	Applicable network
Nil	Without driver	—	—
B2	LECSB2-T9	200 to 240	Pulse input/Point table

7 I/O cable length [m]*4

Nil	Without cable
H	Connector only
1	1.5

*4 When "Without driver" is selected for driver type, only "Nil: Without cable" can be selected.

Compatible Driver

Driver type	Pulse input type
	
Series	LECSB-T
Number of point tables	Up to 255
Pulse input	○
Applicable network	—
Control encoder	Absolute 22-bit encoder
Communication function	USB communication, RS422 communication
Power supply voltage [V]	200 to 240 VAC (50/60 Hz)

Specifications

Actuator specifications	Stroke [mm]	500, 1000, 1500			
	Lead [mm]	50	25	10	
Work load [kg]	Horizontal	3000 [mm/s ²]	60	150	400
		5000 [mm/s ²]	43	93	150
		9800 [mm/s ²]	22	36	—
	Vertical	3000 [mm/s ²]	14	29	80
		5000 [mm/s ²]	12	29	30
		9800 [mm/s ²]	8	9	—
Max. speed [mm/s]	Stroke range	500	2300	1250	500
		1000	1600	800	320
		1500	900	450	180
Max. acceleration/deceleration [mm/s ²]		9800			
Positioning repeatability [mm]		±0.01			
Lost motion [mm]		0.05 or less			
Impact/Vibration resistance [m/s ²]		50/20			
Actuation type		Ball screw			
Guide type		Linear guide			
Operating temperature range [°C]		5 to 40			
Operating humidity range [%RH]		90 or less (No condensation)			
Electric specifications	Motor output [W]/Size [mm]	750/□80			
	Motor type	AC servo motor (200 VAC)			
Encoder		Absolute 22-bit encoder (Resolution: 4194304 p/rev)			
Lock unit specifications	Type	Non-magnetizing lock			
	Holding thrust [N]	240	480	1200	
	Rated voltage [V]	24 VDC ⁰ / _{-10%}			

Construction

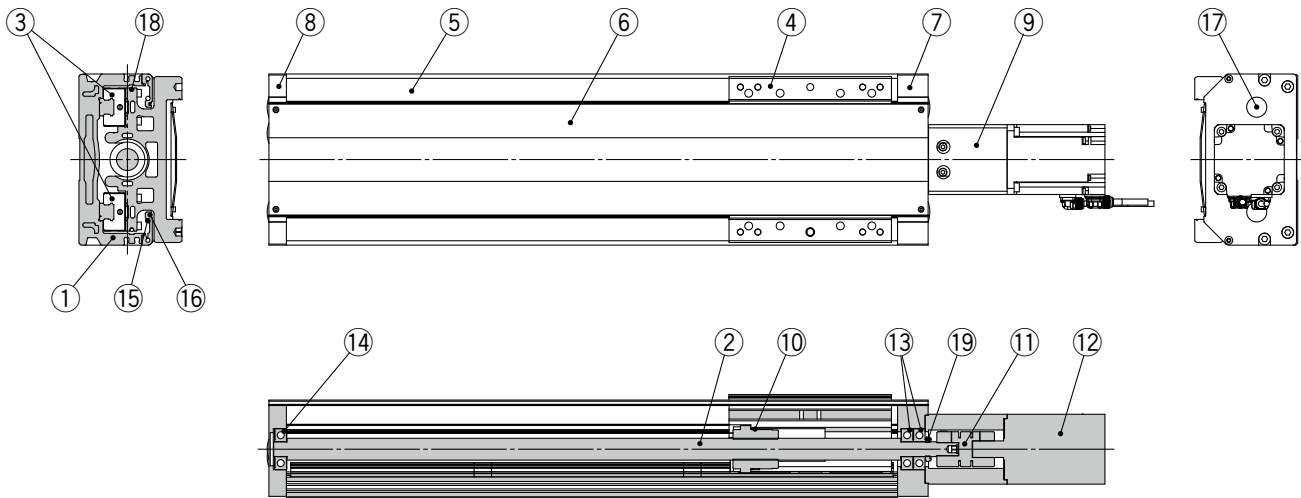

Component Parts

No.	Description	Material	Note
1	Body	Aluminum alloy	Anodized
2	Ball screw assembly	—	
3	Linear guide assembly	—	
4	Table	Aluminum alloy	Anodized
5	Side cover	Aluminum alloy	Anodized
6	Dust cover	Aluminum alloy	Anodized
7	Plate M	Aluminum alloy	Anodized
8	Plate E	Aluminum alloy	Anodized
9	Motor block	Aluminum alloy	Anodized
10	Spacer	Aluminum alloy	"Lead: H" only
11	Coupling	—	
12	Motor	—	
13	Bearing	—	
14	Bearing	—	
15	Pin	Carbon steel	
16	Pin	Carbon steel	
17	Cap	Polyethylene	
18	Magnet	—	
19	Lock nut	—	

LEJS100-X400

AC Servo Motor

Dimensions: Ball Screw Drive

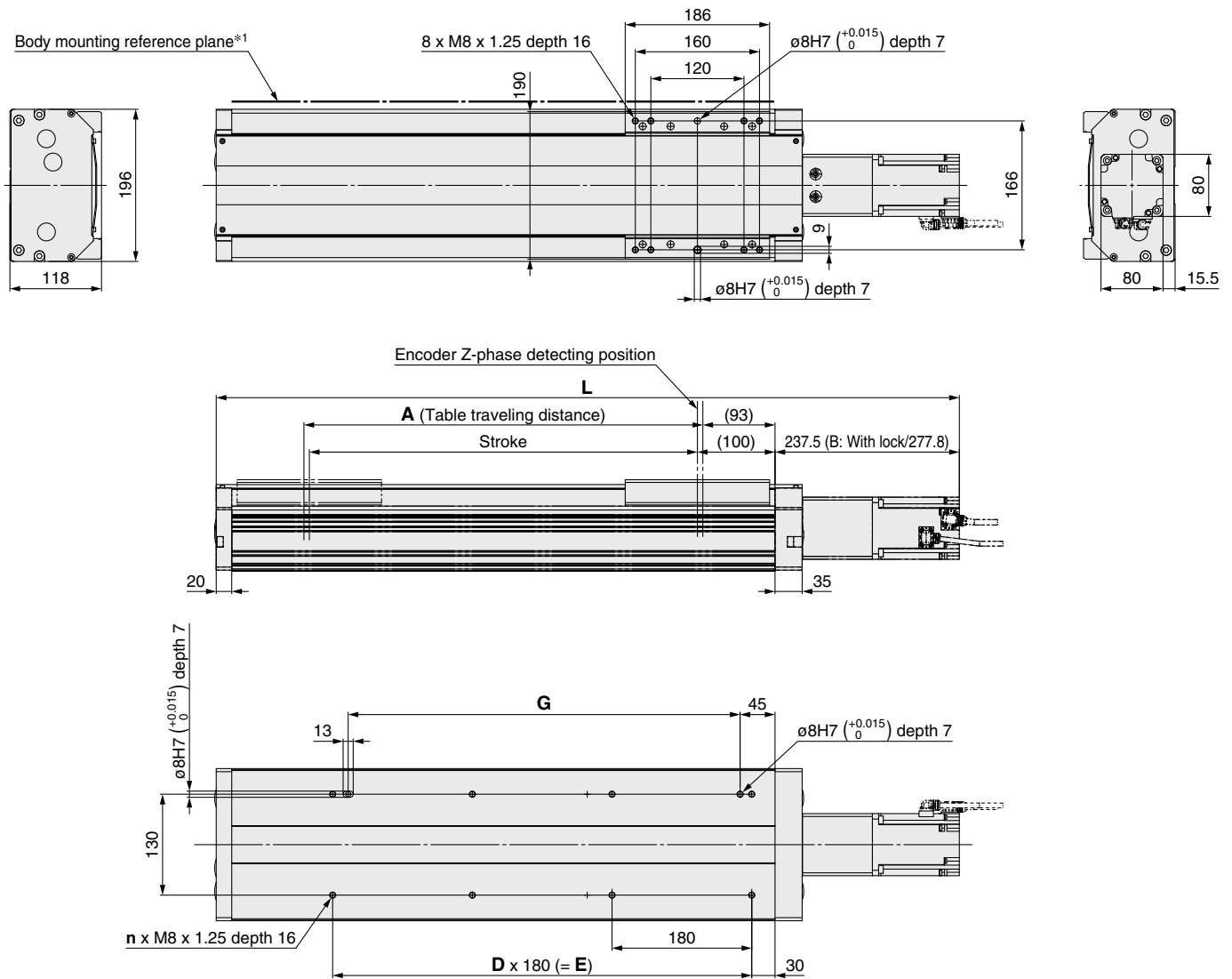

*1 Use a pin when mounting the actuator using the body mounting reference plane. Set the height of the pin to be 5 mm or more because of round chamfering. (Recommended height 6 mm)

* Please consult with SMC for adjusting the Z-phase detecting position at the stroke end of the end side.

Dimensions and Weight

Stroke	L		A	n	D	E	G	Weight [kg]	
	Without lock	With lock						Without lock	With lock
500	957.5	997.8	514	8	3	540	505	26.7	27.7
1000	1457.5	1497.8	1014	14	6	1080	1045	37.1	38.1
1500	1957.5	1997.8	1514	20	9	1620	1585	47.6	48.6

AC Servo Motor Driver Absolute Type

LECSB-T (Pulse input type/Positioning type)



How to Order

LECSB 2-T9

Driver type
B Pulse input type/Positioning type
 (For absolute encoder)

Power supply voltage
2 200 to 240 VAC 50/60 Hz

Compatible motor type

Symbol	Type	Capacity	Encoder
T9	AC servo motor (T9*1)	750 W	Absolute

*1 The symbol shows the motor type (actuator).

* If an I/O connector is required, order the part number "LE-CSNB" separately.
 * If an I/O cable is required, order the part number "LEC-CSNB-1" separately.
 (Since the electric actuator will not operate without forced stop (EM2) wiring when using the LECSB-T in any mode other than positioning mode, an I/O connector or an I/O cable is required.)

Dimensions

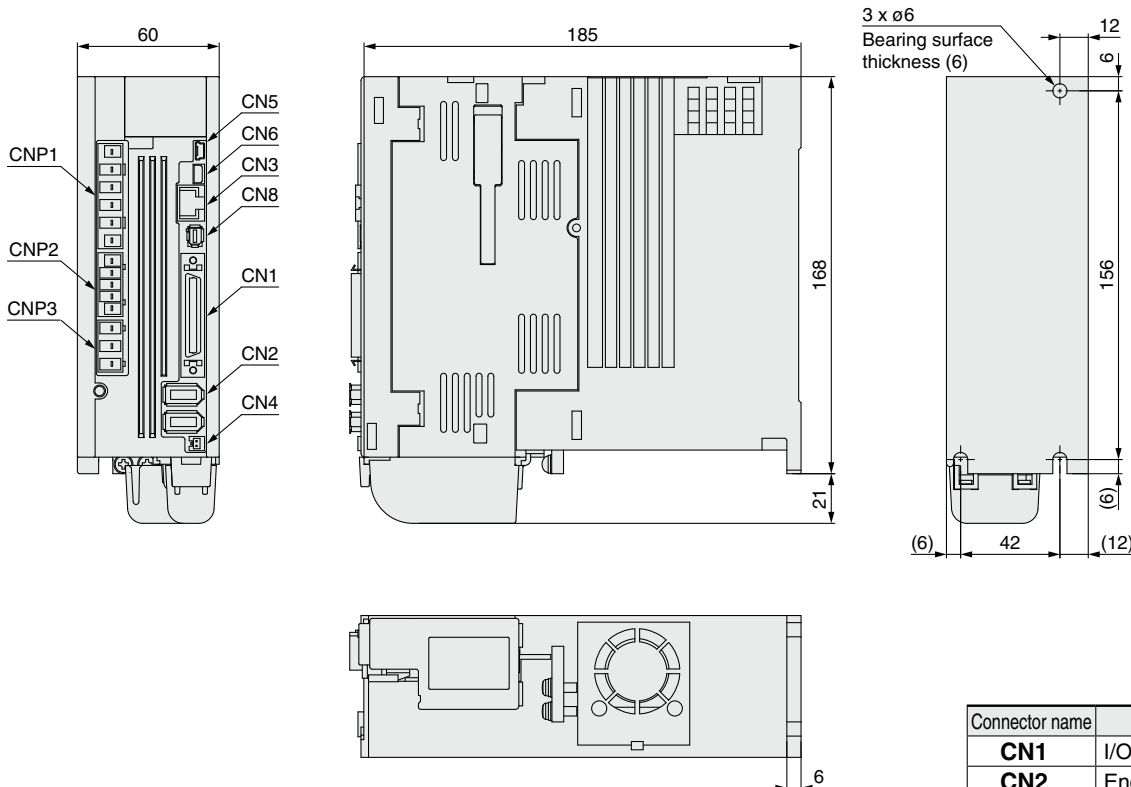

Connector name	Description
CN1	I/O signal connector
CN2	Encoder connector
CN3	RS-422 communication connector
CN4	Battery connector
CN5	USB communication connector
CN6	Analog monitor connector
CN8	STO input signal connector
CNP1	Main circuit power supply connector
CNP2	Control circuit power supply connector
CNP3	Servo motor power connector

LECSB-T

Specifications

Model		LECSB2-T9
Compatible motor capacity [W]		750
Compatible encoder		Absolute 22-bit encoder (Resolution: 4194304 p/rev)
Main power supply	Power voltage [V]	Three phase 200 to 240 VAC (50/60 Hz), Single phase 200 to 240 VAC (50/60 Hz)
	Allowable voltage fluctuation [V]	Three phase 170 to 264 VAC (50/60 Hz), Single phase 170 to 264 VAC (50/60 Hz)
	Rated current [A]	3.8
Control power supply	Control power supply voltage [V]	Single phase 200 to 240 VAC (50/60 Hz)
	Allowable voltage fluctuation [V]	Single phase 170 to 264 VAC
	Rated current [A]	0.2
Parallel input		10 inputs
Parallel output		6 outputs
Max. input pulse frequency [pps]		4 M (for differential receiver), 200 k (for open collector)
Function	In-position range setting [pulse]	0 to ± 65535 (Command pulse unit)
	Error excessive	± 3 rotations
	Torque limit	Parameter setting or external analog input setting (0 to 10 VDC)
	Communication	USB communication, RS422 communication*1
	Point table	Up to 255 points
	Pushing operation	Point table no. input method, Up to 127 points
Operating temperature range [°C]		0 to 55 (No freezing)
Operating humidity range [%RH]		90 or less (No condensation)
Storage temperature range [°C]		-20 to 65 (No freezing)
Storage humidity range [%RH]		90 or less (No condensation)
Insulation resistance [MΩ]		Between the housing and SG: 10 (500 VDC)
Weight [g]		1400

*1 USB communication and RS422 communication cannot be performed at the same time.

Motorless Type

Electric Actuator/High Rigidity Slider Type Ball Screw Drive **LEJS100-X400**



RoHS

How to Order

LEJS100 N B - 500 T - X400

Motorless type • ① • ② • With top cover type

① Lead [mm]

H	50
A	25
B	10

② Stroke [mm]

500	500
1000	1000
1500	1500

Specifications

		Stroke [mm]	500, 1000, 1500			
		Lead [mm]	50	25	10	
Actuator specifications	Work load [kg]	Horizontal	3000 [mm/s ²]	60	150	400
			5000 [mm/s ²]	43	93	150
			9800 [mm/s ²]	22	36	—
		Vertical	3000 [mm/s ²]	14	29	80
			5000 [mm/s ²]	12	29	30
			9800 [mm/s ²]	8	9	—
Max. speed [mm/s]	Stroke range	500	2300	1250	500	
		1000	1600	800	320	
		1500	900	450	180	
Max. acceleration/deceleration [mm/s ²]		9800				
Positioning repeatability [mm]		±0.01				
Lost motion [mm]		0.05 or less				
Ball screw specifications	Thread size [mm]	ø25				
	Shaft length [mm]	Stroke + 284.5				
Impact/Vibration resistance [m/s ²]		50/20				
Actuation type		Ball screw				
Guide type		Linear guide				
Operating temperature range [°C]		5 to 40				
Operating humidity range [%RH]		90 or less (No condensation)				
Other specifications	Actuation unit weight [kg]	4.58				
	Other inertia [kg·cm ²]	0.43				
	Friction coefficient	0.05				
	Mechanical efficiency	0.8				
Reference motor specifications	Motor shape	□80				
	Motor type	AC servo motor (200 VAC)				
	Rated output capacity [W]	750				
	Rated torque [N·m]	2.4				
	Rated rotation [rpm]	3000				

* Values in this specifications table are the allowable values of the actuator body with the standard motor mounted. Do not use the actuator so that it exceeds these values.

* Before mounting the coupling, remove any dust, oil, etc., adhered to the shaft and the inner surface of the coupling.

* This product does not come with a motor, motor mounting screws, or couplings. They should be prepared separately by the customer.

* Take measures to prevent the loosening of the motor mounting screws.

* Do not allow collisions at either end of the table traveling distance. Additionally, when running the positioning operation, do not set within 7 mm of both ends.

LEJS100-X400

Motorless Type

Dimensions

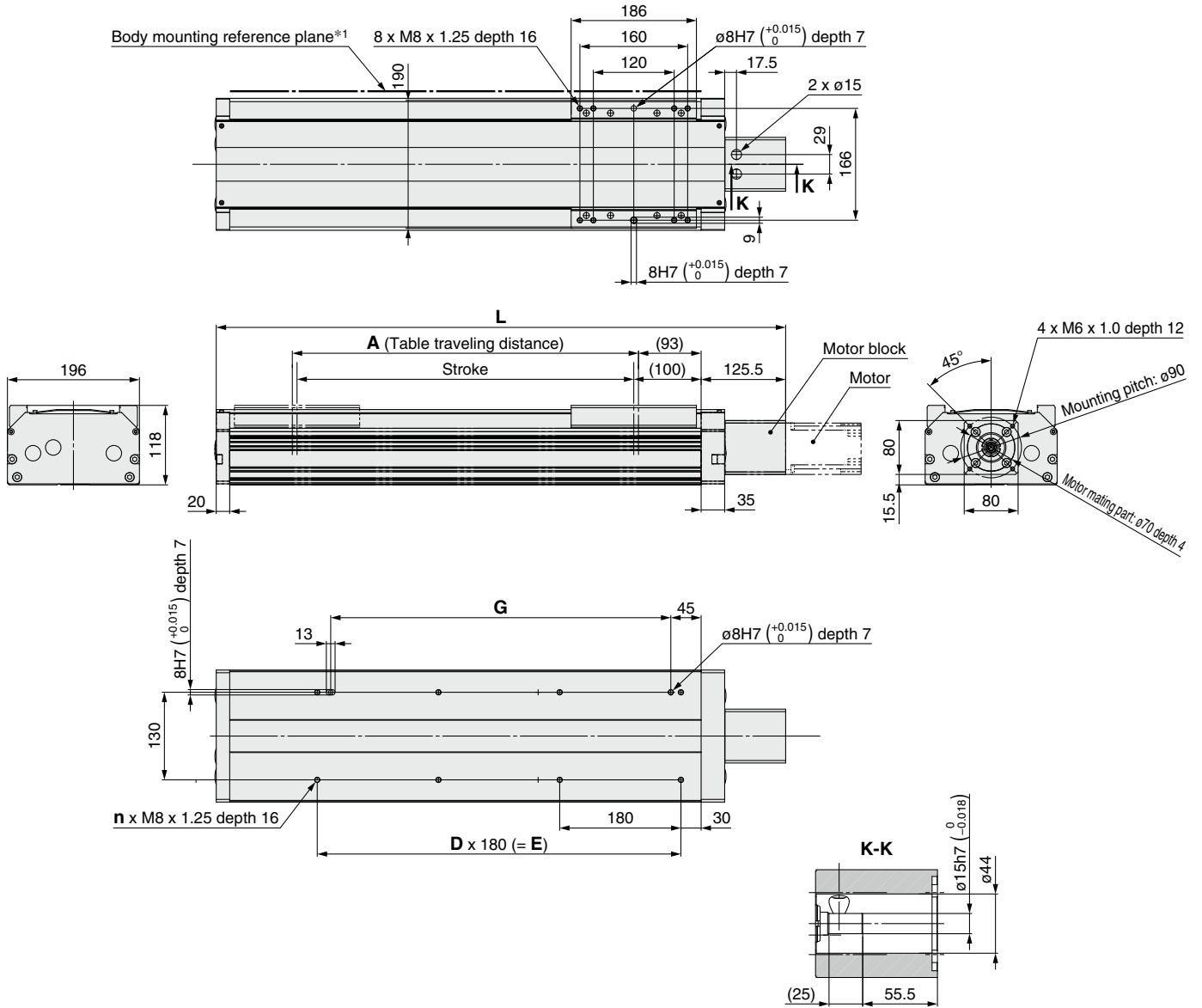

*1 Use a pin when mounting the actuator using the body mounting reference plane or the side supports. Set the height of the pin to be 5 mm or more because of round chamfering. (Recommended height 6 mm)

Dimensions and Weight

Stroke	L	A	n	D	E	G	Weight [kg]
500	845.5	514	8	3	540	505	23.9
1000	1345.5	1014	14	6	1080	1045	34.3
1500	1845.5	1514	20	9	1620	1585	44.8

Side Supports

Side supports: MY-S50A

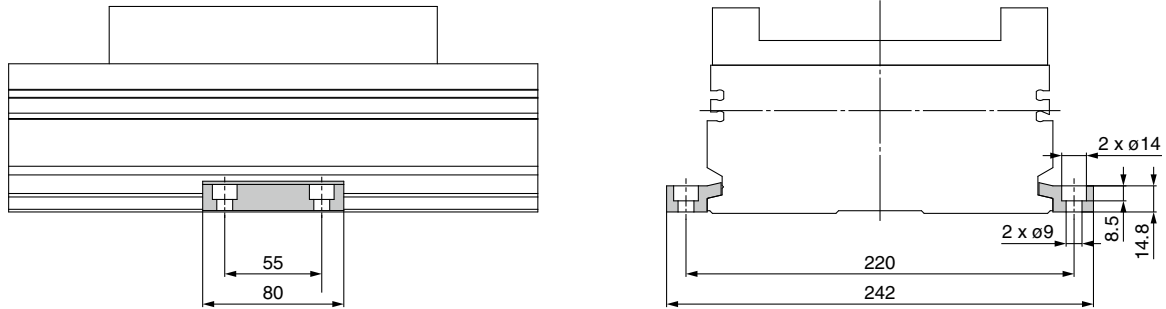

* The side supports consist of a set of right and left brackets.

Usage Guide for Side Supports

When mounting with the side supports, be sure to use the number of side supports (N) and the support spacing (L1 and L2) shown in the figure and table below as a guide.

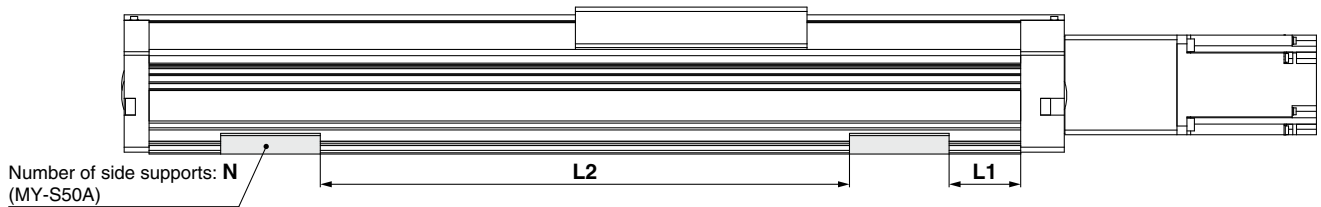

Stroke	N (Qty.)	L1 [mm]	L2 [mm]	Screw size	Max. tightening torque [N·m]
500 st	6	15	165	M8 x 1.25	12.5
1000 st	10		175		
1500 st	14		180		

- When mounting with the side supports, use in combination with the pin on the bottom of the body.
- For vertical or bottom mounting, please refrain from using only the side supports.

Auto Switch Mounting

When mounting an auto switch, first, hold a switch spacer between your fingers and press it into the auto switch mounting groove. When doing this, confirm that it is set in the correct mounting orientation, or reattach it if necessary. Next, insert an auto switch into the auto switch mounting groove and slide it until it is positioned under the switch spacer. After establishing the mounting position, use a flathead watchmaker's screwdriver to tighten the included auto switch mounting screw.

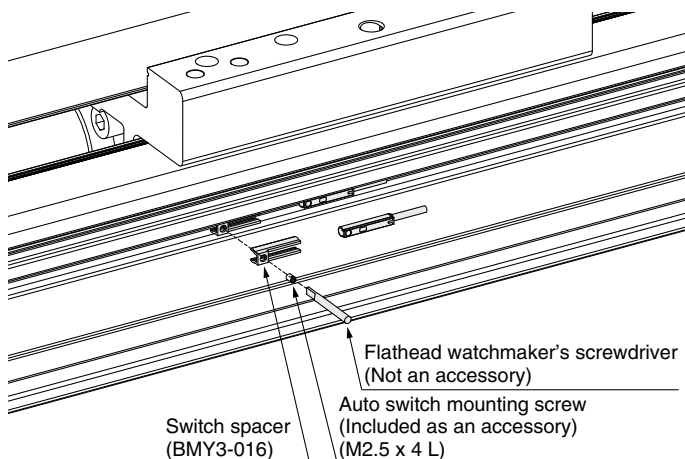

Auto Switch Mounting Screw Tightening Torque

Auto switch model	Tightening torque
D-M9□(V)	0.10 to 0.15
D-M9□W(V)	

 **Safety Instructions** Be sure to read the "Handling Precautions for SMC Products" (M-E03-3) and "Operation Manual" before use.