



Operation Manual

High Vacuum Angle Valve

PRODUCT NAME

XLGR Series

MODEL/ Series

Thank you for purchasing this SMC product.

Be sure to read this Operation Manual carefully and understand its contents before operating this product to ensure the safety of the operator and this product.

Please refer to the drawing and other informative documents for the construction and specifications of this product.

Further, ensure your operating environment satisfies the requirements specified for the product.

Keep this Operation Manual available whenever necessary.

SMC Corporation

Contents

Safety Instructions	-----	2
1. Product Specific Precautions 1 (Precautions on Design, Selection, Mounting, Piping, Wiring, Maintenance)	-----	4
2. Product Specific Precautions 2 (Maintenance parts)	-----	6
3. Specifications	-----	8
4. Construction	-----	9
5. Operation	-----	10
6. Dimensions	-----	11
7. Guaranteed term and guaranteed range	-----	12
8. Parts replacement procedure	-----	13



Safety Instructions

These safety instructions are intended to prevent hazardous situations and/or equipment damage. These instructions indicate the level of potential hazard with the labels of “Caution,” “Warning” or “Danger.”

They are all important notes for safety and must be followed in addition to International Standards (ISO/IEC)*1), and other safety regulations.

*1) ISO 4414: Pneumatic fluid power -- General rules relating to systems

ISO 4413: Hydraulic fluid power -- General rules relating to systems

IEC 60204-1: Safety of machinery -- Electrical equipment of machines (Part 1: General requirements)

ISO 10218-1992: Manipulating industrial robots -- Safety



Caution

Caution indicates a hazard with a low level of risk which, if not avoided, could result in minor or moderate injury.



Warning

Warning indicates a hazard with a medium level of risk which, if not avoided, could result in death or serious injury.



Danger

Danger indicates a hazard with a high level of risk which, if not avoided, will result in death or serious injury.

Warning

1. The compatibility of the product is the responsibility of the person who designs the equipment or decides its specifications.

Since the product specified here is used under various operating conditions, its compatibility with specific equipment must be decided by the person who designs the equipment or decides its specifications based on necessary analysis and test results.

The expected performance and safety assurance of the equipment will be the responsibility of the person who has determined its compatibility with the product.

This person should also continuously review all specifications of the product referring to its latest catalog information, with a view to giving due consideration to any possibility of equipment failure when configuring the equipment.

2. Only personnel with appropriate training should operate machinery and equipment.

The product specified here may become unsafe if handled incorrectly.

The assembly, operation and maintenance of machines or equipment including our products must be performed by an operator who is appropriately trained and experienced.

3. Do not service or attempt to remove product and machinery/equipment until safety is confirmed.

1. The inspection and maintenance of machinery/equipment should only be performed after measures to prevent falling or runaway of the driven objects have been confirmed.

2. When the product is to be removed, confirm that the safety measures as mentioned above are implemented and the power from any appropriate source is cut, and read and understand the specific product precautions of all relevant products carefully.

3. Before machinery/equipment is restarted, take measures to prevent unexpected operation and malfunction.

4. Contact SMC beforehand and take special consideration of safety measures if the product is to be used in any of the following conditions.

1. Conditions and environments outside of the given specifications, or use outdoors or in a place exposed to direct sunlight.

2. Installation on equipment in conjunction with atomic energy, railways, air navigation, space, shipping, vehicles, military, medical treatment, combustion and recreation, or equipment in contact with food and beverages, emergency stop circuits, clutch and brake circuits in press applications, safety equipment or other applications unsuitable for the standard specifications described in the product catalog.

3. An application which could have negative effects on people, property, or animals requiring special safety analysis.

4. Use in an interlock circuit, which requires the provision of double interlock for possible failure by using a mechanical protective function, and periodical checks to confirm proper operation.



Safety Instructions

Caution

1.The product is provided for use in manufacturing industries.

The product herein described is basically provided for peaceful use in manufacturing industries. If considering using the product in other industries, consult SMC beforehand and exchange specifications or a contract if necessary.
If anything is unclear, contact your nearest sales branch.

Limited warranty and Disclaimer/Compliance Requirements

The product used is subject to the following “Limited warranty and Disclaimer” and “Compliance Requirements”.

Read and accept them before using the product.

Limited warranty and Disclaimer

- 1.The warranty period of the product is 1 year in service or 1.5 years after the product is delivered.*2)**
Also, the product may have specified durability, running distance or replacement parts. Please consult your nearest sales branch.
- 2.For any failure or damage reported within the warranty period which is clearly our responsibility, a replacement product or necessary parts will be provided.**
This limited warranty applies only to our product independently, and not to any other damage incurred due to the failure of the product.
- 3.Prior to using SMC products, please read and understand the warranty terms and disclaimers noted in the specified catalog for the particular products.**

***2) Vacuum pads are excluded from this 1 year warranty.**

A vacuum pad is a consumable part, so it is warranted for a year after it is delivered.

Also, even within the warranty period, the wear of a product due to the use of the vacuum pad or failure due to the deterioration of rubber material are not covered by the limited warranty.

Compliance Requirements

- 1.The use of SMC products with production equipment for the manufacture of weapons of mass destruction(WMD) or any other weapon is strictly prohibited.**
- 2. The exports of SMC products or technology from one country to another are governed by the relevant security laws and regulation of the countries involved in the transaction. Prior to the shipment of a SMC product to another country, assure that all local rules governing that export are known and followed.**

1. Product Specific Precautions 1



Common Precautions 1

Be sure to read before handling.

Design



Warning

- All models

1. The body material is A6063 and A5052. Bellows material is SUS316L. Internal vacuum valve components are SUS304 or A6061. The sealing material of the vacuum part is FKM as standard, but this can be changed to other materials (refer to “How to Order”). Confirm whether the fluid to be used is compatible with the materials before use.

Grease for vacuum is applied to the sliding part of the vacuum (Fluorine grease: Y-VAC2).

2. Select materials for the pilot pressure piping and fittings whose heat resistance is suitable for the applicable operating temperature.

- Models with auto switch

1. Keep the temperature of the switch below 60 °C.

Selection



Caution

- All models

1. When controlling valve responsiveness, take note of the size and length of piping, as well as the flow rate characteristics of the actuating solenoid valve.

2. Keep the pilot pressure within the specified range.

3. Keep within the specified range of the pilot pressure. 0.4 MPa to 0.5 MPa is recommended.

- High temperature type

1. If using gases that cause a large amount of deposits, heat the valve body to prevent deposits in the valve.

Mounting



Caution

- All models

1. In high humidity environments, keep the valve packed until the time of installation.

2. For models with switches, secure the lead wires so that they have sufficient slack, without any unreasonable force applied to them.

3. Perform piping so that excessive force is not applied to the flange sections. When there is vibration from heavy objects or attachments, etc., fix piping so that vibration will not apply torque directly to the flange section.

- High temperature type (temperature specification / H0)

1. If the valve is to be insulated, only the body should be insulated, excluding the bonnet part.

Piping



Caution

1. Before mounting, clean the surface of the flange seal and the O-ring with ethanol, etc.

2. There is an indentation of 0.1 to 0.2mm in order to protect the flange seal surface, and it should be handled so that the seal surface is not damaged in any way.

 **Warning**

If the fluid or reaction product (deposit) may cause the valve to become unsafe, the valve should be disassembled, cleaned and re-assembled by an operator who has sufficient knowledge and experience (e.g. a specialist).

 **Caution**

1. When removing deposits from the valve, take care not to damage any part of it.
2. Replace the bonnet assembly when the valve is approaching the end of its service life.
*For the endurance cycles, refer to Section 5 (page 12).
3. If damage is suspected prior to the end of the service life, perform early maintenance.
4. SMC specified parts should be used for service. Refer to the Construction / Maintenance parts table.
5. When removing the valve seal and external seal, take care not to damage the sealing surfaces. When installing the valve seal and external seal, be sure that the O-ring is not twisted.

2. Product Specific Precautions 2



Common Precautions 2 Be sure to read before handling

Maintenance Parts



- SMC specified parts should be used for service. Refer to the construction drawing.
1. Replace the bonnet assembly when changing the sealant material. Due to the different materials used, changing only the seal may prove inadequate.

Bonnet assembly (Construction part no.) 1

Temperature Specifications	Valve size		
	80	100	160
For general environments	XLG80-30-1-1	XLG100-30-1-1	XLG160-30-1-1
For high temperature	XLG80-30-1H-1	XLG100-30-1H-1	XLG160-30-1H-1

Note1) The magnet for auto switch is not provided. When the magnet for auto switch is necessary, add "-M9/" at the suffix of the part number.

Note2) An auto switch for high temperature is available with a different part number.

Note3) List the optional sealant material symbol after the model number, except for the standard sealant material (FKM: compound No. 1349-80).

Note4) The bonnet assembly includes valve seals.

Bypass valve Construction number: (9)

Temperature Specifications	Common for all sizes
General purpose	XLA-16*-X65
For high temperature	XLA-16*H0-X65

Note1) Auto switch is not included in the bypass valve. Contact SMC if you need auto switch.

Note2) The "*" in the table refers to the pilot valve mounting orientation. Refer to the catalog of drawing for How to Order.

Note3) O-ring(8) is not included in maintenance part.

Note4) If the sealing material of the bypass valve is not standard (FKM: Composition No.1349-80) Please refer to the catalog of SMC or the drawing for How to Order.

O-ring for replacement

Product name Construction part number	Material	Valve size		
		80	100	160
Main exhaust valve External seal (3)	Standard	AS568-045V	AS568-050V	AS568-167V
	Special	AS568-045 **	AS568-050V **	AS568-167V **
Main exhaust valve Valve seal (2)	Standard	B2401-V85V	AS568-349V	B2401-G155V
	Special	B2401-V85 **	AS568-349V **	B2401-G155V **
Sealing O-ring (8)	Standard	AS568-017V		
	Special	AS568-017 **		
Bypass valve External seal (12)	Standard	AS568-025V		
	Special	AS568-025 **		
Bypass valve Valve seal (11)	Standard	B2401-V15V		
	Special	B2401V15 **		

Note1) List the optional seal material symbol after the model number (in place of **), except for the standard seal material (FKM: Compound No. 1349-80).

Note2) Refer to section "4. Construction" for components numbers.

Note3) We do not guarantee the quality if the seal material is changed by customer.

Note4) Two O-rings (8) are require per valve.

Additional symbols of the seal materials

Seal material	EPDM	Barrel Perfluoro®	Kalrez®	Chemraz®			VMQ	FKM for PLASMA	ULTIC ARMOR®
Combination No.	2101-80.	70W	4079	SS592	SS630	SSE38	1232-70.	3310-75.	UA4640
Symbol	-XN1	-XP1	-XQ1	-XR1	-XR2	-XR3	-XS1	-XT1	-XU1

Note1) Due to the different materials used, changing only the seal may prove inadequate.

Barrel Perfluoro® is a registered trademark of MATSUMURA OIL Co.,Ltd.

Kalrez® is a registered trademark of DuPont Performance Elastomers.

Chemraz® is a registered trademark of Greene, Tweed & Co.,

ULTIC ARMOR® is a registered trademark of NIPPON VALQUA INDUSTRIES, LTD.

Grease for maintenance Part no.

Description	Common for all sizes
Vacuum grease	FONMBLIN Y VAC 2 (Solvay Solexis)

3. Specifications

Model		XLGR-80*-1*	XLGR-100*-1*	XLGR-160*-1*
Valve size		80	100	160
Actuating type	Main exhaust valve	Double acting (pressurized to open / close)		
	Bypass valve	Normal close (N.C.)		
Fluid		Vacuum of inert gas		
Ambient temperature: 20°C		5 to 60 (5 to 150 for high temperature type)		
Operating pressure Pa		Atmospheric pressure to 1×10^{-5}		
Conductance l/s Note 1	Main exhaust valve	200	300	800
	Bypass valve	MAX31.5 (Viscosity / Theoretical value)		
Leakage Pam ³ /s	Internal	1.3 x 10 ⁻⁹ for the standard material (FKM) at ambient temperature, excluding gas permeation		
	External	1.3 x 10 ⁻⁹ for the standard material (FKM) at ambient temperature, excluding gas permeation		
Flange type		KF (NW) ,K (DN)		
Main material Note 2		Body :A6063,A50521 Critical part :SUS304,A6061 Bellows (Bypass valve): SUS316L Seal material: FKM		
Surface treatment for body		Outside: hard anodized Inside: basis material		
Pilot pressure MPa		0.4 to 0.6		
Port size	Main exhaust valve	Rc1/8		
	Bypass valve	M5		
Air consumption cm ³ Note 3	Main exhaust valve	1000	2300	3700
	Bypass valve	16		
Weight kg		4.9	8.3	15.7

Note1) Conductance is "molecular flow" measured with an elbow pipe which has the same dimension as each applicable flange.

Note2) The seal sliding part for vacuum uses vacuum grease (Y-VAC2).

Note3) For one cycle of cylinder.

Bypass valve conductance < for Reference only >

The graph to the right is to show the relationship between the bypass valve adjusting screw.

The data shown is based on internal SMC experimentation. The results found in the actual application may vary. Please verify settings for each individual application.

Please refer to "5-2. Adjusting the bypass valve" for adjustment procedure.

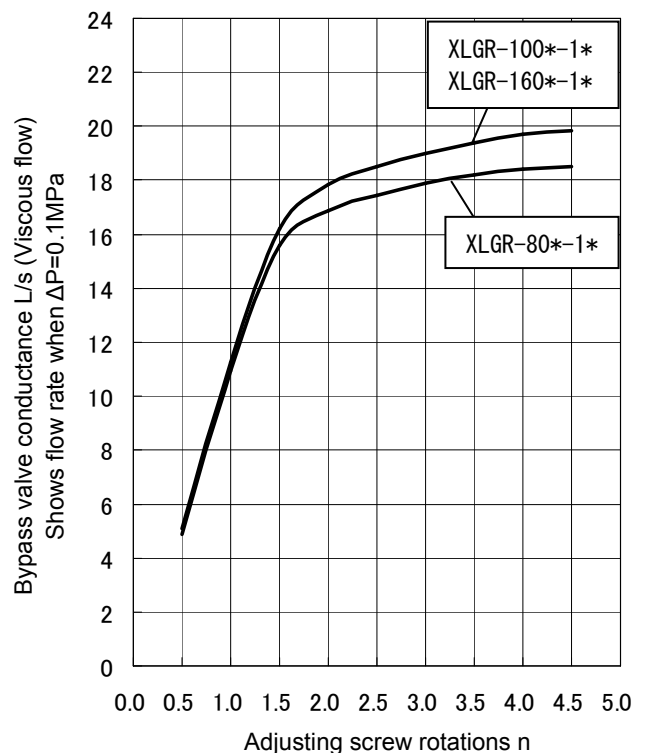

4. Construction

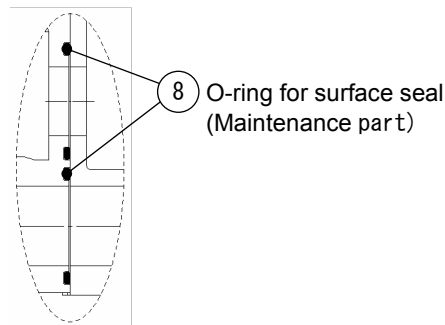
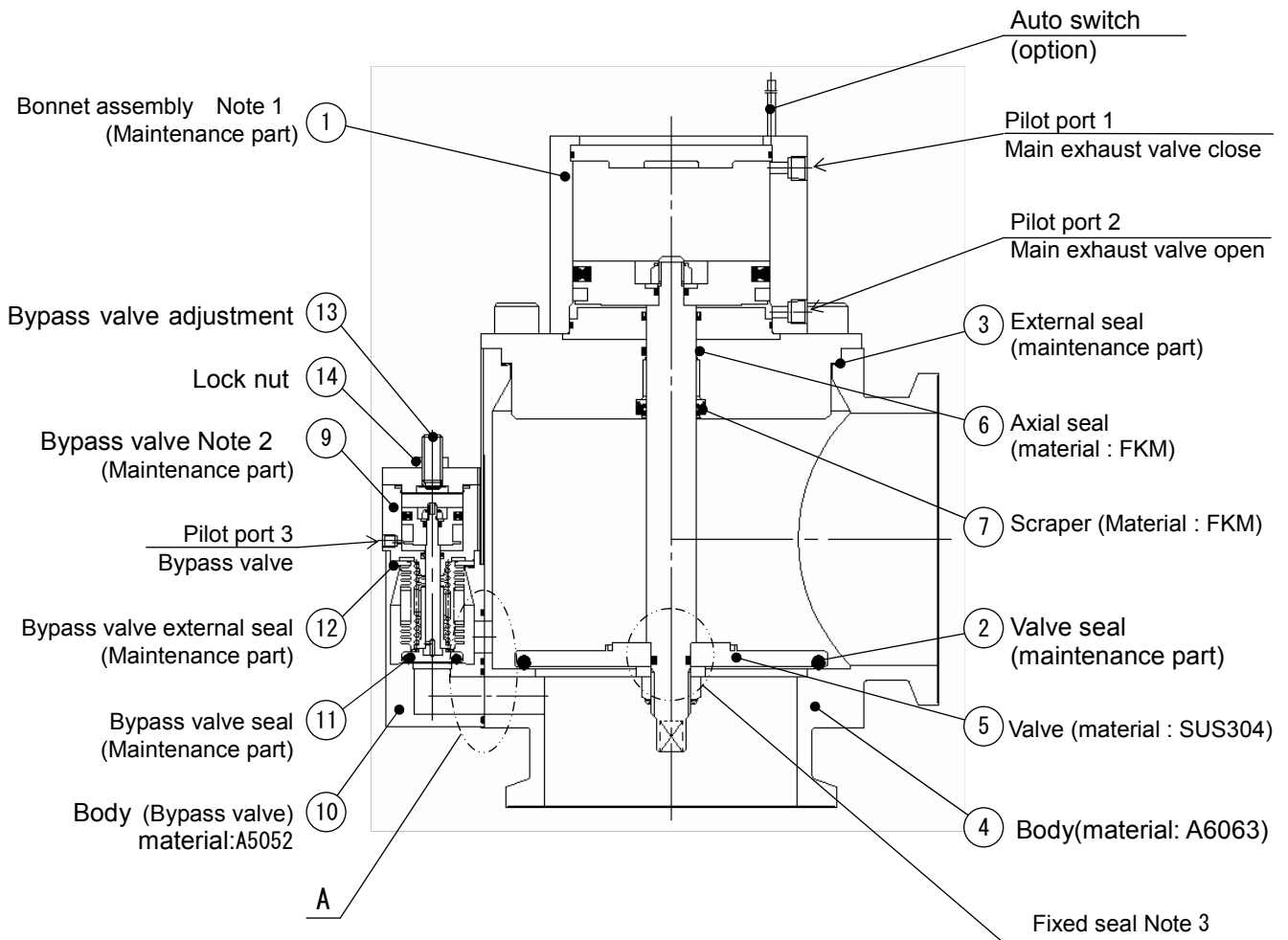

Detail of A

Note1) (3) external seal is not included in bonnet assembly.

Note2) (8) O-ring is not included in the bypass valve.

Note3) Vacuum grease is applied to (6)axis seal, (7)scraper, (8)O ring for surface seal and fixed seal.

5. Operation

5-1. Operation

1. Main exhaust valve

The valve sits in the body seat to seal by applying pressure to the pilot port 1.

(Pilot port 2 opens)

The valve leaves from the body seat to open by applying pressure to the pilot port 2.

(Open pilot port 1)

2. Bypass valve

The valve leaves from the body seat to open up to the set value by applying pressure to the pilot port 3. The valve returns to the original position by releasing air pressure of the pilot port 3.

5-2. Adjusting the bypass valve

Adjust the open degree of the bypass valve before use. Bypass valve is adjusted by changing the open degree of the valve. Bypass valve stroke can be adjusted from 1 to 5mm (Note 1).

1. Loosen lock nut(14) to release locking.

Hold bypass valve adjusting bolt(13) with hexagon wrench to loosen the lock nut. (Fig.1)

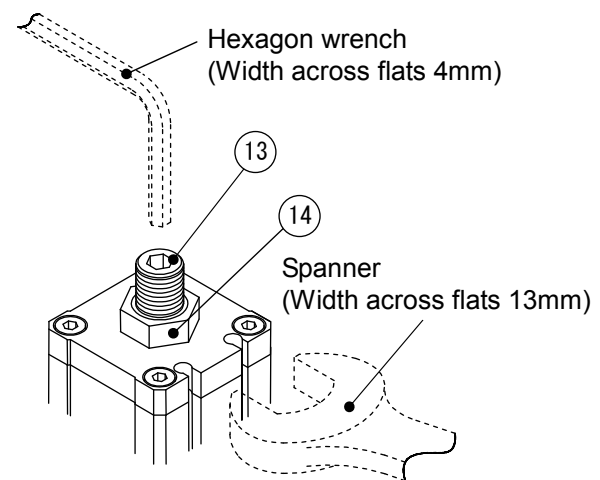

Fig.1

2. Keep turning bypass valve adjusting bolt(13) clockwise.

Open amount becomes zero when it stops turning lightly. (Fig.2)

Open amount becomes larger by turning counterclockwise.

- Adjustment pitch : 1mm/turn

3. Tighten lock nut(14) when adjustment completed.

Note1) To avoid the damage of O-ring and adjustment part, do not turn bypass valve adjusting bolt(13) farther than the point where turning is stopped at both ends.

Note2) Do not apply pressure to the operation port during adjustment.

Note3) Bypass valve is fully open at ex-factory.

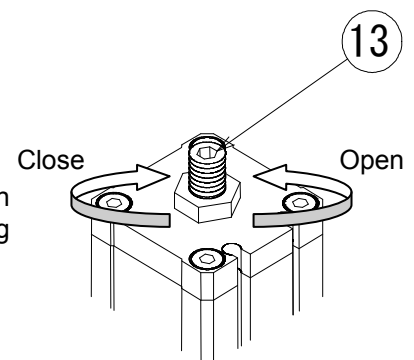
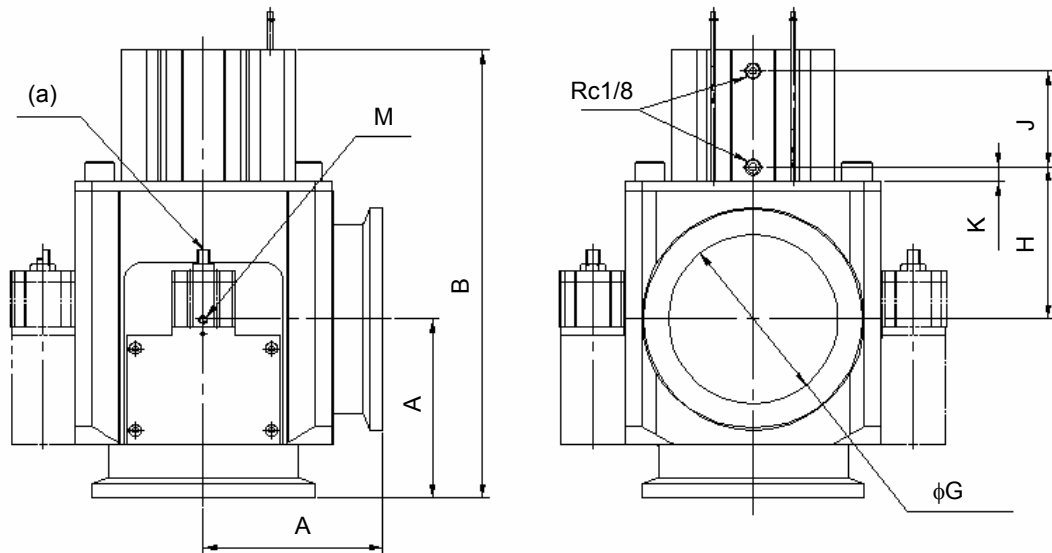
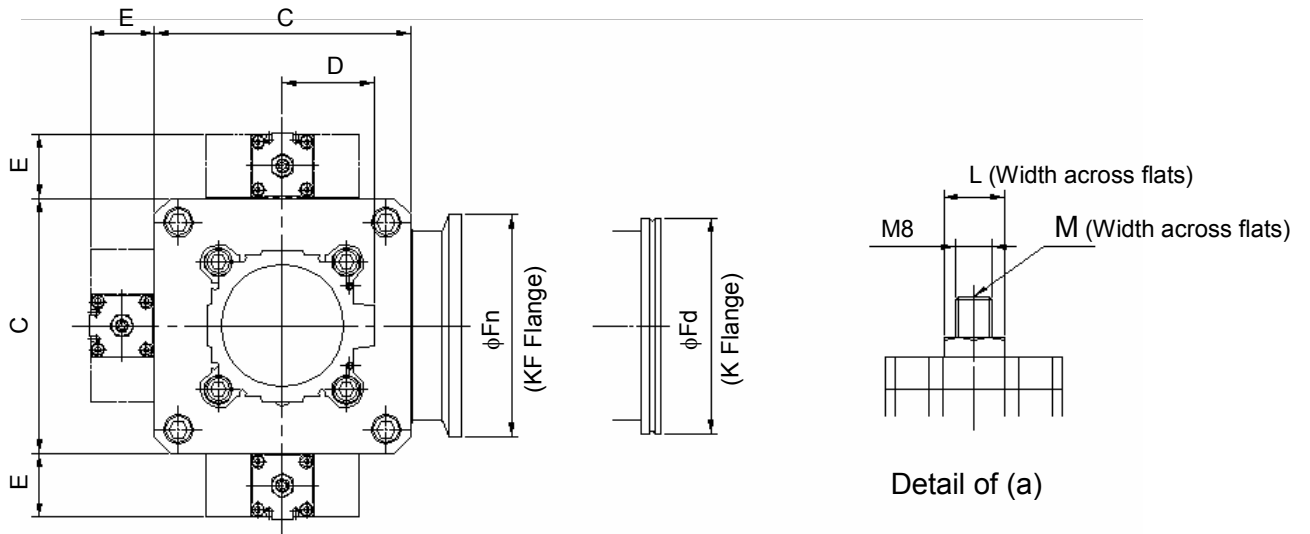

Fig.2

6. Dimensions



Model	A	B	C	D	E	Fn	Fd
XLGR-80*-1*	90	250	117	45.5	38.5	114	110
XLGR-100*-1*	108	270.5	154	55	38.5	130	102
XLGR-160*-1*	138	339	200	65	38.5	180	153

Model	G	H	J	K	L	M
XLGR-80*-1*	83	105	44	9	13	4
XLGR-100*-1*	102	92	58	9	13	4
XLGR-160*-1*	153	124	62	12.5	13	4

7. Guaranteed term and guaranteed range

The warranty period is 2 million cycles (for size 80) or 1 million cycles (for size 100 and 160) (under SMC endurance test conditions), 18 months after delivery or 12 months in service, whichever comes first.

If the valve has been used outside of the specifications, or if a failure occurs as a result of mounting onto a machine or replacement of an assembly, O-ring etc. by the user, the guarantee cannot be applied.

Notes: The endurance will depend on the operating conditions (such as if the flow rate is large).

For any failure reported within the warranty period which is clearly our responsibility, the whole valve will be replaced. This guarantee does not apply to any damage incurred due to the failure of the valve.

Result of endurance test

(with the circuit shown on the right)

The valve was opened and closed in an internal vacuum state at an ordinary (room) temperature and checked for internal and external leakage and operation.

It was confirmed that XLG-80 satisfied it up to 2 million cycles, XLG-100 and XLG-160 satisfied it up to 1 million cycles.

The test was performed with FKM, the standard sealant material.

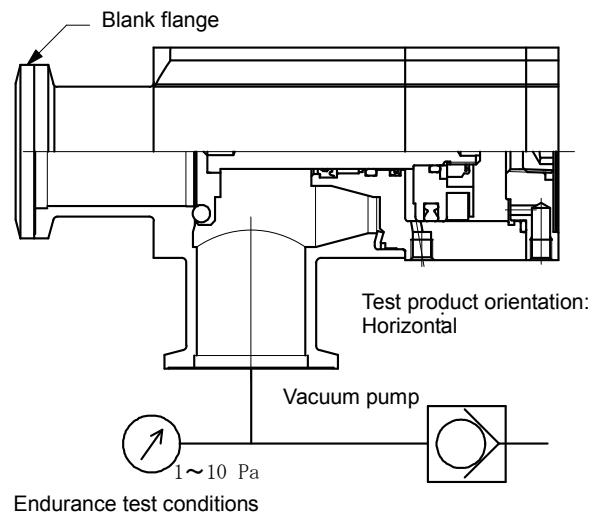

<Reference>

The pumping direction is not limited, but if the pumping creates a flow stream, the durability of the product could be impaired.

Therefore, the pumping direction shown on the right figure (bellows side pumping) is recommended. Also, the operating conditions should be checked beforehand because it affects the life.

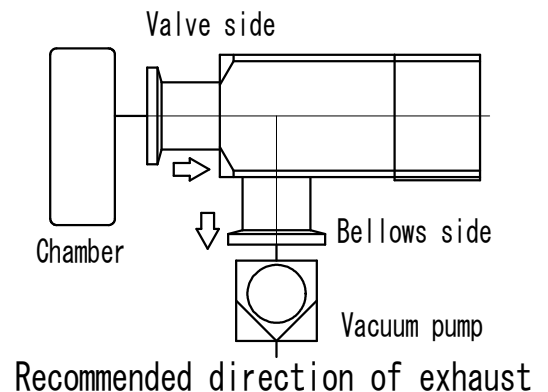

8. Parts Replacement Procedure

8-1. Precautions

Be sure to follow [1. Precautions 1] when disassembling the product for maintenance. Along with the precautions above, comply with the following precautions too.

Warning

- If it is expected that product materials may get stuck to the product, ensure safety is assured before handling. It is recommended to wear gloves and a mask.
- Pay attention to the handling of components according to the procedure in the next item onwards. Do not apply excessive force or impact. This will not only damage the product but also decrease its performance and life expectancy.
- It is not possible to disassemble the bonnet assembly of this product. If the components and assembly are damaged, or damage is expected, exchange the bonnet assembly itself.
- Do not disassemble the parts that are not explained in this operation manual. The performance and life may decrease. Also, it may cause danger.

8-2. Main exhaust valve disassembly procedure

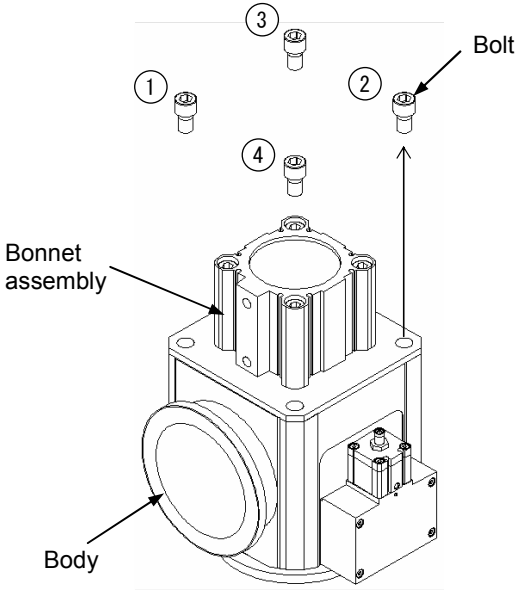
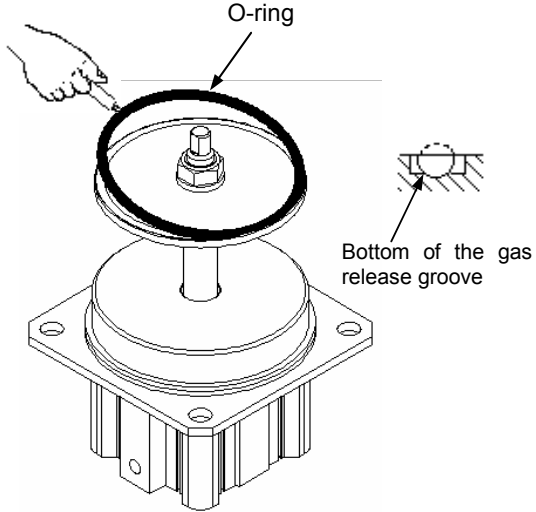
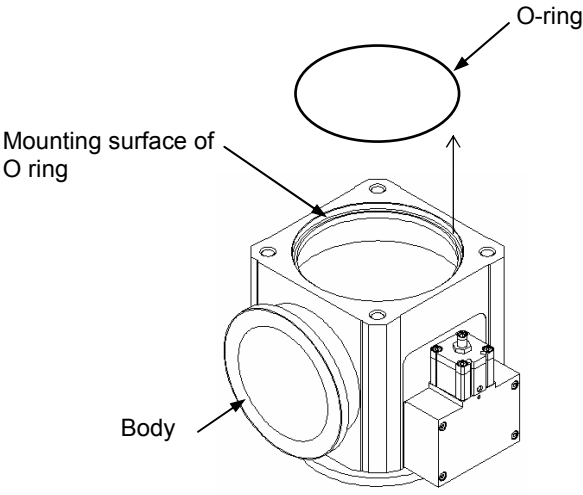
<p style="text-align: center;">Step 1</p>  <p>Disassemble the body and the bonnet assembly by gradually loosening the hexagon socket head cap screws.</p>	<p style="text-align: center;">Step 2</p>  <p>Remove the O-ring from the gas release part of the O-ring groove with a tool whose height is as the same as the depth of the gas release part. (Be careful not to damage the O-ring groove.)</p>
<p style="text-align: center;">Step 3</p>  <p>Remove the outer seal O ring from the body <Take care to prevent the mounting surface of O ring from being damaged></p>	

8-3. Main exhaust valve disassembly procedure

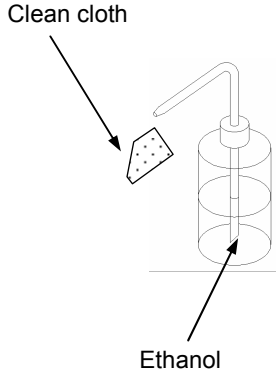
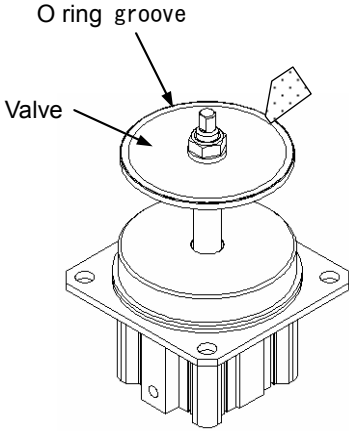
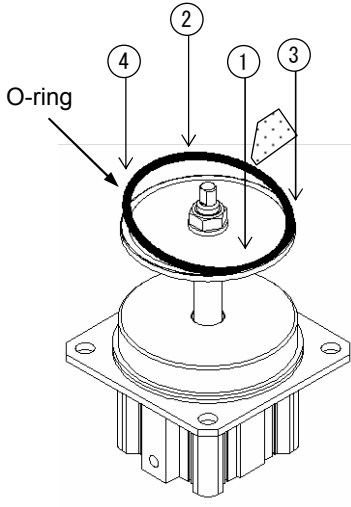
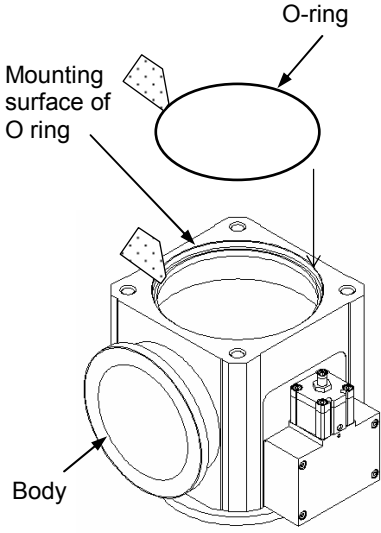
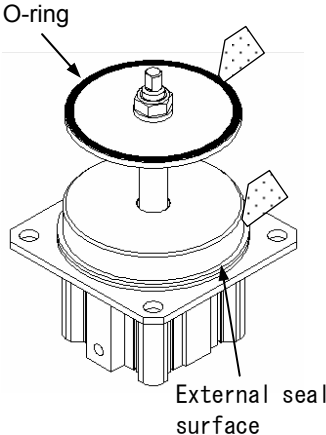
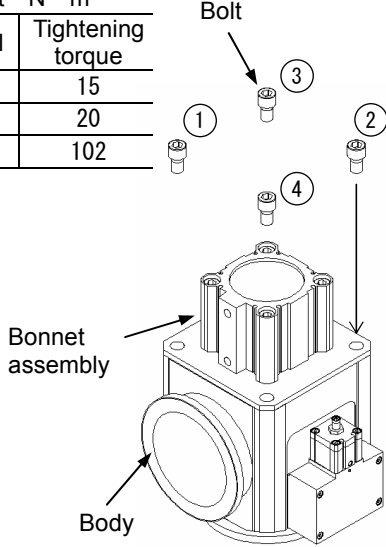
Step 1	Step 2	Step 3								
 <p>Clean cloth</p> <p>Ethanol</p> <p>Assemble parts eliminating dust. Wipe off dust with a clean cloth soaked with ethanol. Blow parts with clean air if necessary. (Ensure there is no fiber or dust)</p>	 <p>O ring groove</p> <p>Valve</p> <p>Eliminate the dust of O ring groove of pilot valve.</p>	 <p>O-ring</p> <p>Wipe off the dust on the valve seal O ring surface. Place the O ring on the O ring groove. Press the O-ring into the groove in numerical order (press diagonally) to fit the O-ring into the groove. Take care not to twist the O ring. <Use dust-free gloves></p>								
 <p>O-ring</p> <p>Mounting surface of O ring</p> <p>Body</p> <p>Wipe off the dust from the external seal O ring surface and the mounting surface of the body O ring. Place the O ring on the O ring mounting surface.</p>	 <p>O-ring</p> <p>External seal surface</p> <p>Wipe off dust from valve seal O-ring and the external seal surface.</p>	<p>Tightening torque of bolt N · m</p> <table border="1" data-bbox="997 1196 1230 1352"> <thead> <tr> <th>Model</th> <th>Tightening torque</th> </tr> </thead> <tbody> <tr> <td>80</td> <td>15</td> </tr> <tr> <td>100</td> <td>20</td> </tr> <tr> <td>160</td> <td>102</td> </tr> </tbody> </table>  <p>Bolt</p> <p>Bonnet assembly</p> <p>Body</p> <p>Assemble Body and Bonnet assembly by tightening the bolts in numerical order. Manually tighten Bolts until O-ring is compressed. Perform final torque with same numerical order.</p>	Model	Tightening torque	80	15	100	20	160	102
Model	Tightening torque									
80	15									
100	20									
160	102									

8-4. Bypass valve disassembly procedure

Step 1

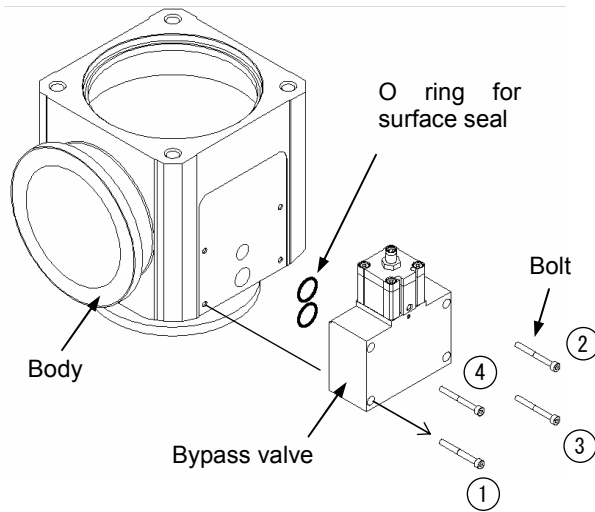

Remove Bypass valve from Body by loosening the hexagon socket head cap screws in numerical order. Remove two O rings for surface seal.
 < Take care not to scratch the groove of O ring to prevent seal leak. >

Step 2

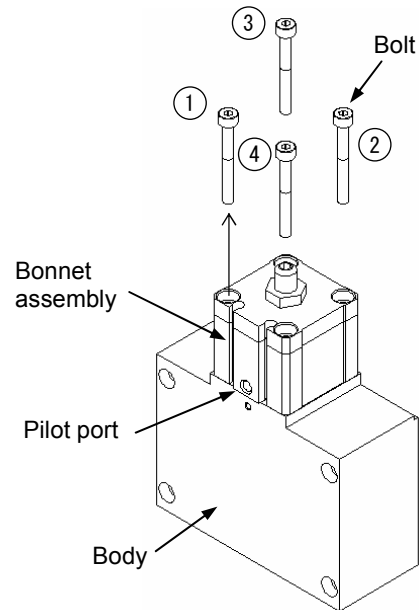

Apply 0.4MPa of air pressure to the pilot port of Bypass valve. Loosen bolts in numerical order to disassemble the Bonnet from Body assembly.

Step 3

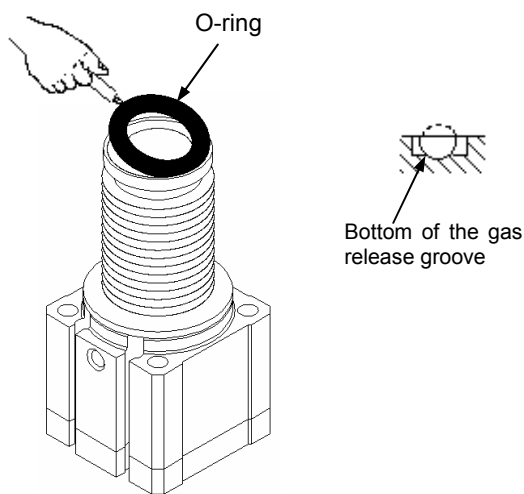

Remove the O-ring from the groove for discharging gas using a plastic tool to prevent scratch the O-ring groove.
 <Take care not to scratch the groove of O ring. >

Step 4

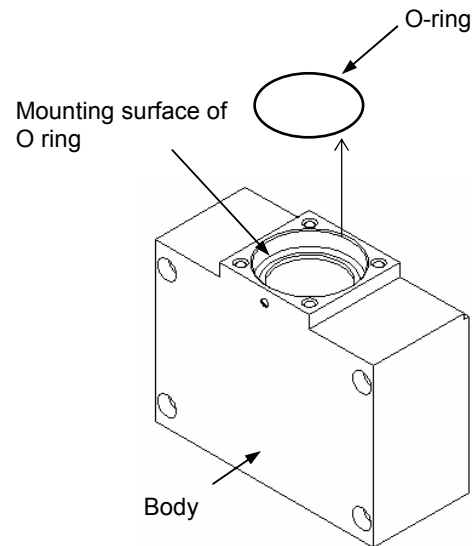

Remove the outer seal O-ring from the Body
 <Take care to prevent the mounting surface of O ring from being damaged and free of debris. >

8-5. Bypass valve assembly procedure

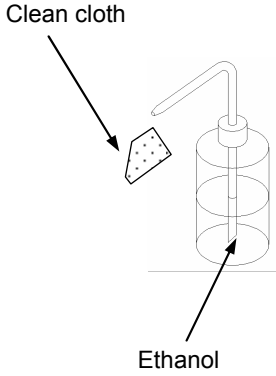
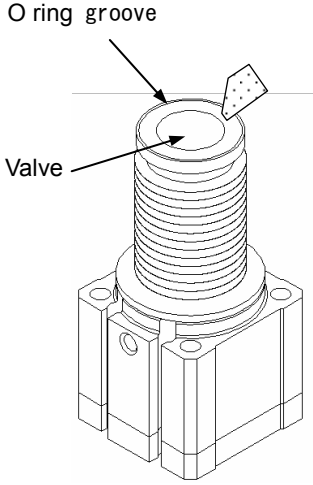
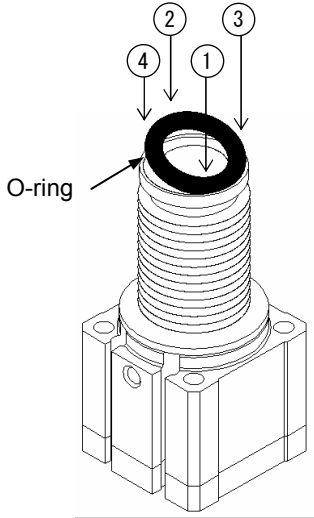
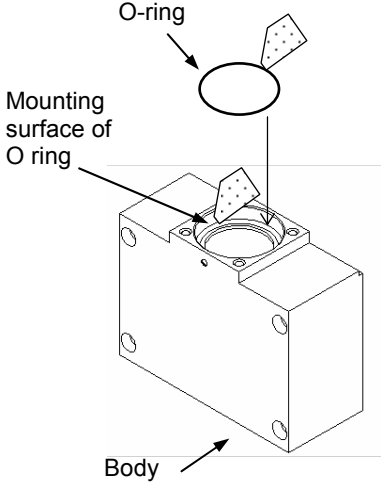
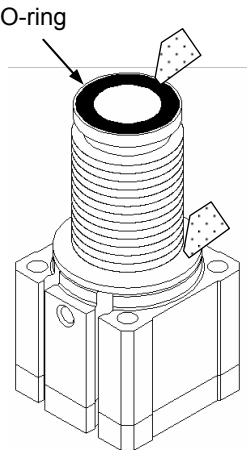
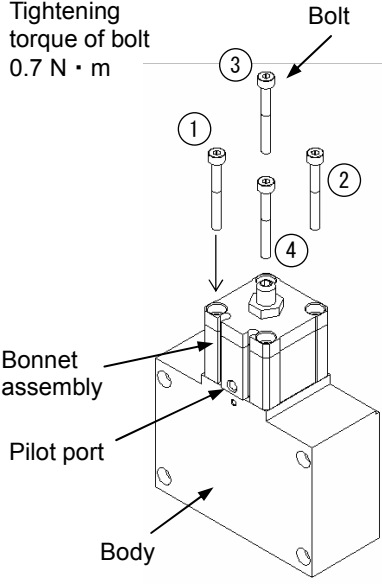
<p style="text-align: center;">Step 1</p>  <p>Clean cloth</p> <p>Ethanol</p> <p>Assemble parts eliminating any dust or debris. Wipe off dust with a clean cloth soaked with ethanol. Blow parts with clean air if necessary. < Ensure there is no fibers or dust. ></p>	<p style="text-align: center;">Step 2</p>  <p>O ring groove</p> <p>Valve</p> <p>Eliminate any dust within O-ring groove of the valve.</p>	<p style="text-align: center;">Step 3</p>  <p>O-ring</p> <p>Wipe off any dust on the valve seal O ring surface. Place the O ring on the O ring groove. Press the O-ring into the groove in numerical order. Take care not to twist the O ring. <Use dust-free gloves></p>
<p style="text-align: center;">Step 4</p>  <p>O-ring</p> <p>Mounting surface of O ring</p> <p>Body</p> <p>Wipe off any dust from the external O-ring seal and the mounting surface of the Body. Place the O-ring on the O-ring mounting surface.</p>	<p style="text-align: center;">Step 5</p>  <p>O-ring</p> <p>Wipe off any dust from the valve seal O-ring and the external seal surface.</p>	<p style="text-align: center;">Step 6</p>  <p>Tightening torque of bolt 0.7 N · m</p> <p>Bolt</p> <p>Bonnet assembly</p> <p>Pilot port</p> <p>Body</p> <p>Assemble Body and Bonnet assembly by tightening the bolt in numerical order. Manually tighten bolts until O-ring is compressed. Perform final torque with same numerical order.</p>

Step 7

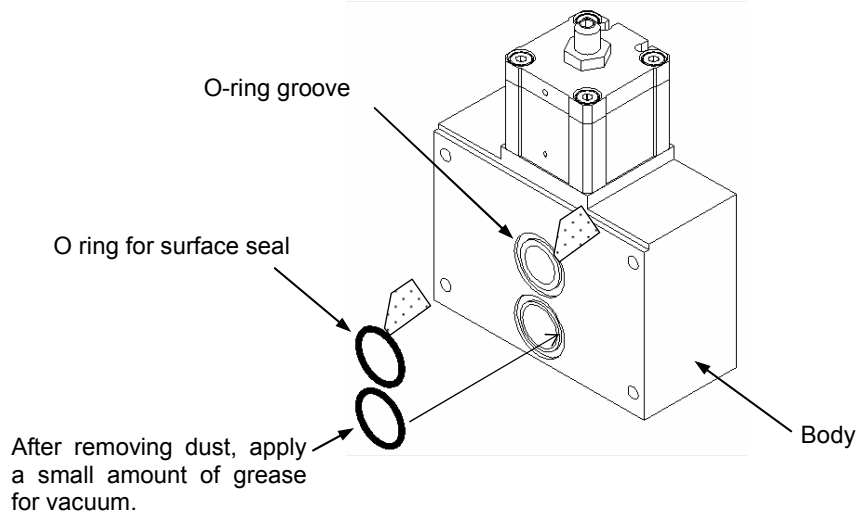

After removing dust from O-ring for surface seal, apply a small amount of grease for vacuum (Y VAC2). Apply vacuum grease evenly on the entire O ring. Remove the dust O ring groove on the Bypass valve body before assembling.

Step 8

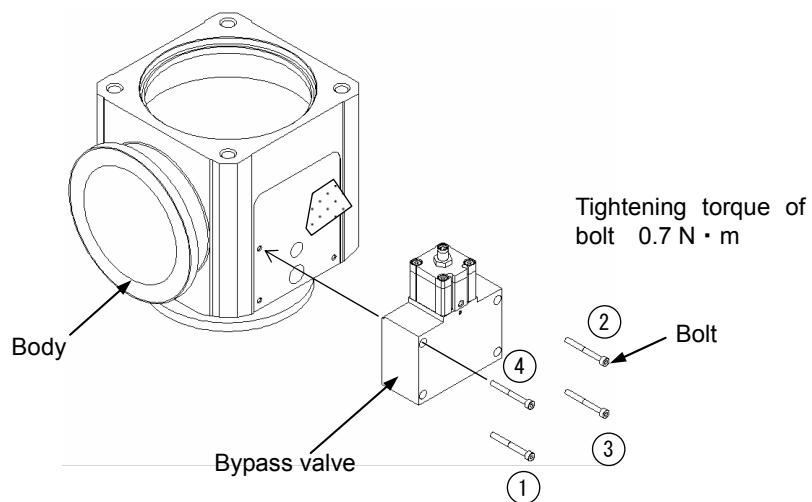

Remove the dust from the main exhaust valve body seat surface. Tighten the bolts in numerical order to attach the bypass valve. Manually tighten bolts until O-ring is compressed. Perform final torque with same numerical order.

Revision history

1st Printing :PR

SMC Corporation

4-14-1, Sotokanda, Chiyoda-ku, Tokyo 101-0021 JAPAN
Tel: + 81 3 5207 8249 Fax: +81 3 5298 5362
URL <http://www.smcworld.com>

Note: Specifications are subject to change without prior notice and any obligation on the part of the manufacturer.
© 2009 SMC Corporation All Rights Reserved