





Electric Cylinder LZC series
Operation Manual
SMC Corporation

1. Safety Instruction

These instructions indicate the level of potential hazard by labels of "Warning" and "Caution". To ensure safety, be sure to observe ISO 10218 /JIS B8433 and other safety practices.

-  Warning: Operator error could result in serious injury or loss of life.
-  Caution: Operator error could result in injury or equipment damage.

Symbols

Symbol	Explanation
	Symbol meaning warning and caution. Contents are instructed by figure or phrase in the symbol.
	Symbol meaning do not operate are instructed by figure or phrase in the symbol.
	Symbol meaning operate are instructed by figure or phrase in the symbol.

Operator

- This manual is for the person in charge of assembly, operation, and maintaining of machinery and device with electric control equipment who has enough knowledge and experience.
- The manual must be read through before assembly, operation and maintenance.

Application limit

* This product aims at application for common factory automation equipment. Do not use LZC for machinery and devices (*1) that directly concern human life or those which malfunction or failure could cause serious damage.

- *1: Machinery and devices that directly concern human life are;
- Life support system or medical equipment
 - Device obligated by Laws and regulation such as Fire protection law and Building code.
 - Equipment and devices which comply with above.

*Contact SMC Sales office before use on any of the following relating to human safety and that have an impact on public utilities(*2). Special consideration(*3) is necessary for the management, maintenance and control of the system.







*2: Systems relating to human safety that have an impact on the public utilities are;

- Main machine control and nuclear plant control systems, safety protection systems, nuclear installation systems, and other systems important for safety.
- Drive control and flight control systems of public transport systems.
- Equipment and devices in contact with food and beverage.





*3: Special consideration means to discuss with SMC engineers, and to construct a safe system(The foolproof design, the fail safe design, and design using redundancy circuits).

- Special consideration for safety and security to prevent the risk of damage by failure and malfunction caused by the occurrence of environmental stress (change over time).

 Warning

	- Do not overhaul or modify parts (incl. circuit board). It might cause injury or failure.
	- Do not operate or set with wet hand. It might cause electric shock.
	- Do not exceed specified operating range. It might cause fire accident, malfunction, and cylinder breakage. Keep within operating range.
	- Do not use in areas containing flammable gas, explosive gas and corrosive gas. It may cause fire, explosion and corrosion. This actuator is not of an explosion proof structure.
	- Do not connect or operate with non-applicable motor, cylinder. It might cause fire, explosion and corrosion.
	- Do not touch the work while the cylinder is operating. It might cause injury.
	- To avoid the risk of damage due to failure and malfunction occurring, establish back-up system such as multiple system equipment/device, fail-safe structure in advance.

 Caution

	- The heat sink of the directional control equipment and the cylinder motor become hot during operation. Do not touch until they are cooled down.
	- Ground FG terminal Without proper grounding, malfunction may occur which could lead to an accident. For better ground efficiency, keep the ground wiring distance short and separate grounding is recommended.
	- Inspect correct function after maintenance. Stop operation when device and equipment does not work correctly. Unexpected malfunction might risk safety of operation. Perform emergency stop and ensure safety.
	- Connect the power and turn on the switch after ensuring the safety of the slider's moving range. Moving slider might cause an accident.

Caution on operation

Design your application using the recommendations shown below.

- Design recommendations
Please read this manual and design accordingly.

- *Specification
- Keep within specified voltage.

- Do not apply a workload that exceeds the max. load capacity.
- Keep maintenance space.

*Handling

- *Mounting
- Do not drop, bump or apply excessive impact.
 - Keep directional control equipment 50mm or more away from inner surface of control box or other equipment.
 - Do not hold by the Guide rod of the cylinder when handling.
 - Keep specified tightening torque.
 - Do not mount the cylinder where it can be trod on.
 - Cylinder should be mounted on a flat surface with machine accuracy or equivalent accuracy.
 - When using mounting feet, always use two.
 - When mounting the work to the rod end, clamp across flats on the rod end for tightening so as not to apply a rotating force to the end.

*Wiring

- Avoid repeatedly bending or stretching the cable.
- Confirm proper wiring
- Do not wire while power applied.
- Do not wire adjacent to power lines or high voltage lines to avoid noise interference.
- Confirm proper insulation of wiring.

*Operating environment

- Avoid use in the following environments.
- Location with a lot of debris, dust, water, chemicals, or oil.
- Location where magnetic field is generated.
- Location where temperature cycles are applied.
- Location where surge voltages are generated.
- Use surge absorption element built-in type when directly operating surge voltage generating load such as the relay and solenoid valve.
- Prepare lightning surge protection on the device.
- Mount where no vibration or impact exists.

*Maintenance

- Periodic maintenance is required.

2. Parts check

Ensure parts below are included in the package.

Parts	Qty.
Main body	1 pc.
Operation manual (This document)	1 copy
Set screw for the male thread (*1)	1 pc.

(*1) Only male thread type (L[ZC][][] - [][][A][L][][]) is included.

Accessory (Only L[ZCL][][] is equipped)

Parts	Qty.
Rod end mounting foot	1 pc.
Housing end mounting foot	1 pc.
Foot mount thread	6 pcs.

3. Parts description

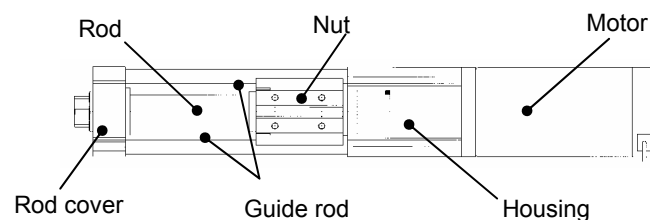

4. Mounting

4-1 Directly mounts onto the rod cover

Fix with 4 holes "H" as shown below.

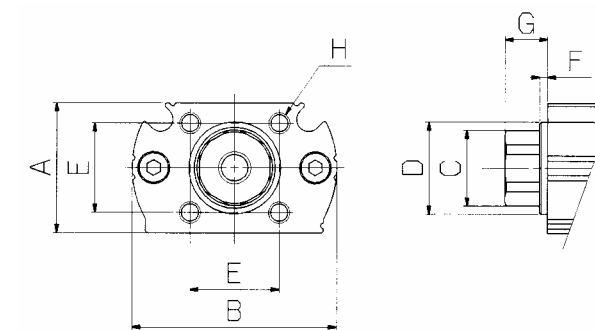

Model no.	A	B	C	D
L[ZC][3][]	24	38	14	17
L[ZC][5][]	38	58	22	27.5

Model no.	F	G	H	[Tightening torque]
L[ZC][3][]	1.5	8	M4 x 0.7 x 6 deep	[0.75N·m]
L[ZC][5][]	3	13	M5 x 0.8 x 8 deep	[1.5N·m]

4-2 Foot mounting

Fix with 4 holes "D" as shown below.

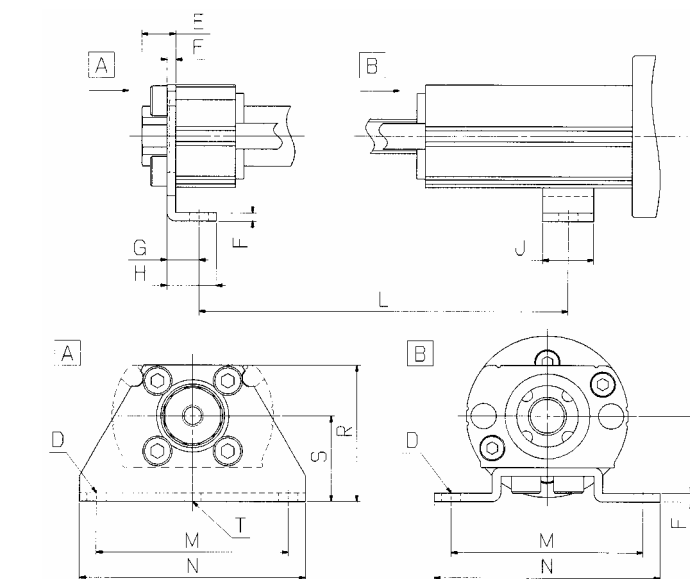

Model no.	D	E	F	G	H	J
L[ZC][3][]	4.5	8	2	7.5	11.5	12
L[ZC][5][]	6.5	13	3.2	10.7	16.7	15

Model no.	M	N	L	S	R	T
L[ZC][3][]	45	53	86.5+st	20	32	4
L[ZC][5][]	64	76	111.5+st	30	49	4

Tightening torque of accessories (foot)

Model	A	B
L[ZC][3][]	M4 screw 0.75Nm	M4 screw 0.75Nm
L[ZC][5][]	M5 screw 1.5Nm	M6 screw 2.6Nm

*Use locking tool when mounting foot.

4-3 Mounting to workpiece

Female thread type

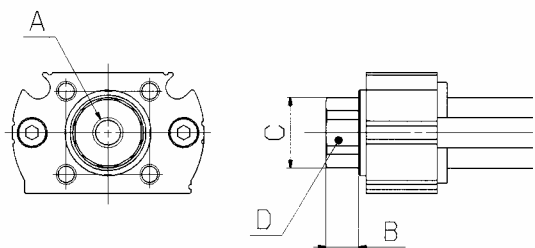

Model no.	A	[Tightening torque]	
L[ZC]3	M6 x 1.0 x 8 deep	[5.2Nm]	
L[ZC]5	M10 x 1.25 x 12 deep	[24.5Nm]	
Model no.	B	C	D
L[ZC]3	8	14	Across flat 13
L[ZC]5	10	22	Across flat 21

Male thread type

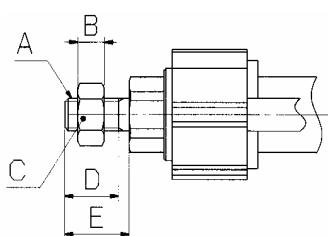

Model no.	A	[Tightening torque]		
L[ZC]3	M6 x 1.0	[3.0N·m]		
L[ZC]5	M10 x 1.25	[24.5N·m]		
Model no.	B	C	D	E
L[ZC]3	5	Across flat 10	10	12
L[ZC]5	6	Across flat 17	19.5	22

Caution

When mounting the workpiece to the rod end, clamp across the end flats when tightening so as not to apply rotating force to the rod.

Do

4-4 Mounting Jig to the piston

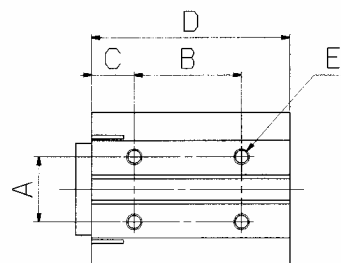

Model no.	E	[Tightening torque]		
L[ZC]3	M3 x 0.5 x 3 deep	[0.315N·m]		
L[ZC]5	M4 x 0.7 x 4 deep	[0.75N·m]		
Model no.	A	B	C	D
L[ZC]3	12	20	8	37
L[ZC]5	16	20	15.5	52.5

4-5 Mounting Auto switch

Full cover type and half cover type can be fitted with auto switches into the mounting groove on the cover.

Select cylinder with built in magnet when auto switches are required.

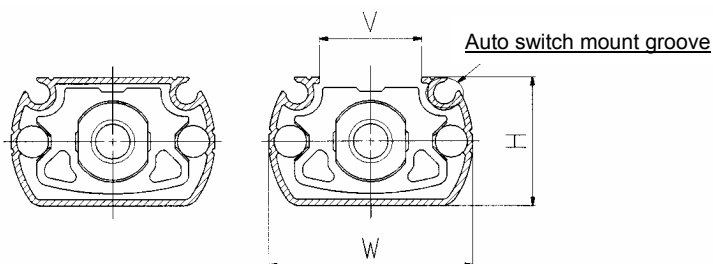

Model no.	W	H	V
L[ZC]3	38	24	19
L[ZC]5	58	38	26.5

5. Wiring

Connect the motor cable to the specified directional control equipment LC3F2 motor output terminal (CN3).

(See "Directional Control Equipment LC3F2 Operation Manual" for details)

CN3 Motor output terminal

Pin No.	Terminal	Function
1	OUTA	Motor output A (Blue line)
2	OUTB	Motor output B (Red line)

Housing : VHR-2N (JST) Contact: BVH-21T-P1.1(JST)

*Protection ground terminal connection

Ground the system using the protection ground terminal on the electric cylinders motor.

L[ZC]3 : M3 x 0.5 x 3 deep

L[ZC]5 : M4 x 0.7 x 3 deep

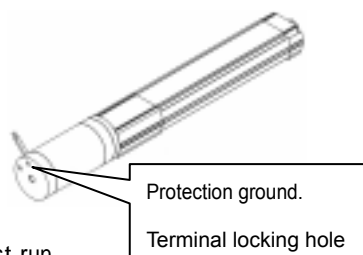

6. Test run

Procedure of adjustment and test run

Perform adjustment and test run after checking the installation and wiring.

(1) Supply power

Indicator lamp (POWER) turns on when applying power to directional control equipment.

(2) Test run

Initiating a signal to the control terminal and the actuator starts.

The actuator may have sudden movement if operated with max. torque.

Set the dial at minimum (counterclockwise), and increase the torque gradually.

Terminal	A-PHASE direction	B-PHASE direction	Stop command
ON	ON	ON	OFF
SET	ON	ON	-
A-PHASE	ON	OFF	-

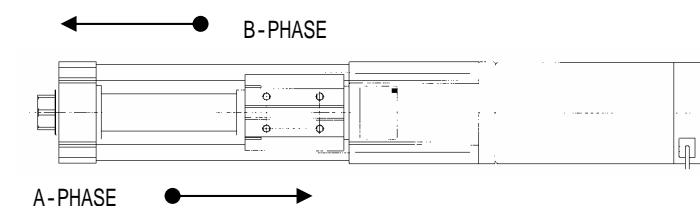

Warning

Do not touch the work during test run and torque adjustment.

Warning

7. Check / Maintenance

7-1 Daily check

Perform inspection before/after operation

Check item	What to check
Appearance	No gouge or nick found on the body. No debris, dust or water adhered.
Motor	If it is too hot.
Cable	No damage, cracked or incorrect wiring.

7-2 Periodic inspection

Inspection every 6 months or the not use for 1month or longer.

Check item	What to check
Mounting to the body	No loose part
Feeding screw sliding part	Rod is not obstructed in operation in allowable moving range

7-3 Life

Reference for energizing time

Model no.	Mounting direction	Energizing time
L[ZC]3	Horizontal	Approx.3,000hrs. (Operation 60%, Holding 40%)
L[ZC]5		Approx.4,000hrs. (Operation 60%, Holding 40%)

Reference of travel depending lead

Model no.	Mount direction	Travel (km)
L[Z]3L	Horizontal	200
L[Z]3M		640
L[Z]3H		1,200
L[Z]5L		280
L[Z]5M		850
L[Z]5H		1,700

Note. Refer to the shorter data shown above.

Reference above is calculated based on the actual life test.

Therefore, the life may be shorter due to the environment or operating conditions.

8. Trouble shooting

Refer to the troubleshooting section of "Operation Manual of Directional Control equipment LC3F2 " when cylinder drive motor does not start or operation stops suddenly.

9. How to Order

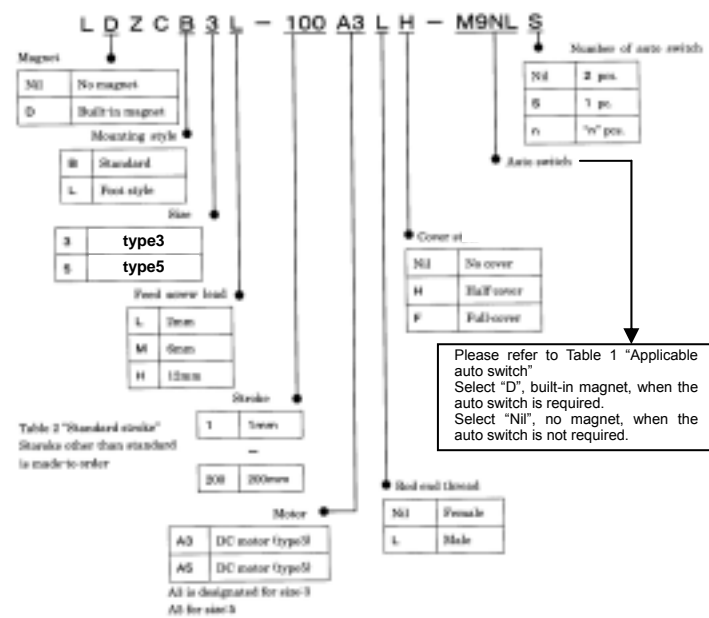

Table 1 Applicable Auto Switch

Auto switch model	Lead wire length symbol(n)		Wiring (Output)	Indicator light
	0.5 (N)	3 (L)		
D-MN	●	●	3wire(NP)	Yes
D-MP	●	●	3wire(PNP)	
D-MG	●	●	2wire	

Table 2 Standard stroke

Stroke	25	40	50	100	200
L203	25	40	50	100	200
L205	25	40	50	100	200

10. Specification

	L[]ZC[]3L- [] [] [] A3	L[]ZC[]3M- [] [] [] A3	L[]ZC[]3H- [] [] [] A3
Mounting direction	Horizontal		
Feed screw lead (mm)	2	6	12
Speed with no load (mm/s)	33 or more	100 or more	200 or more
Rated thrust (N)	80 or more	43 or more	24 or more
Available stroke (mm)	1 - 200 (Std. stroke : 25/40/50/100/200)		
Applicable directional control equipment model	LC3F212-5A3[]		
Applicable auto switch	D-M9[]		
	L[]ZC[]5L- [] [] [] A5	L[]ZC[]5M- [] [] [] A5	L[]ZC[]5H- [] [] [] A5
Mounting direction	Horizontal		
Feed screw lead (mm)	2	6	12
Speed with no load (mm/s)	33 or more	100 or more	200 or more
Rated thrust (N)	196 or more	117 or more	72 or more
Available stroke (mm)	1 - 200 (Std. stroke : 25/40/50/100/200)		
Applicable directional control equipment model	LC3F212-5A5[]		
Applicable auto switch	D-M9[]		

11. Regarding EMC Directive

The EMC directive is applied to the DC motor fitted to the electric cylinder LZ series and the directional control equipment as a combination.

Please refer to the manual of the directional control equipment for the test condition at the third party.

How to use the protection ground terminal:

For the emission noise reduction, ground to the protection ground terminal on the end of motor, using a metal P-clip onto the shielded part of the motor output terminal cable. At the directional control equipment end of the motor output terminal cable attach to the frame ground.

- + The P-clip and the motor output terminal cable to be supplied by the customer.
- If required SMC can also supply the motor output terminal cable by the ordering code as shown below.

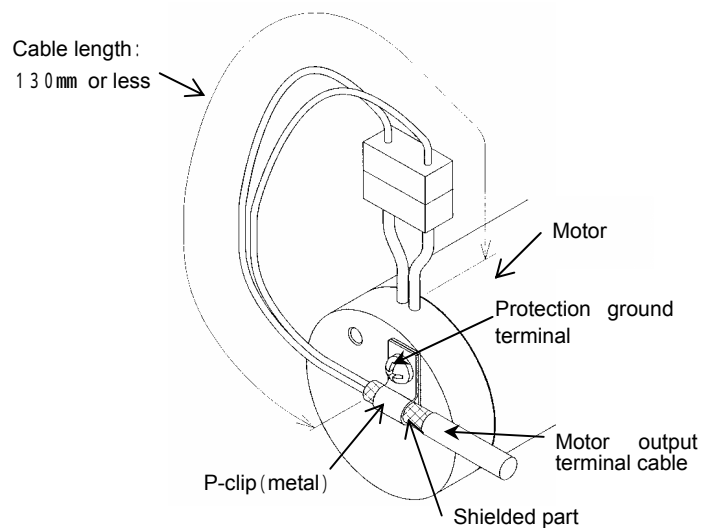

Motor output terminal cable :
LC3F2-1-C3-0.2-1
● Cable length 0.2 : 2m
0.5 : 5m

12. European Contact List

*SMC Corporation

Country	Telephone	Country	Telephone
Austria	(43) 2262-62 280	Italy	(39) 02-927 11
Belgium	(32) 3-355 14 64	Netherlands	(31) 20-531 8888
Czech Republic	(420) 5-414 24611	Norway	(47) 67 12 90 20
Denmark	(45) 70 25 29 00	Poland	(48) 22-548 50 85
Finland	(358) 9-859 580	Portugal	(351) 22 610 89 22
France	(33) 1-64 76 10 00	Spain	(34) 945-18 41 00
Germany	(49) 6103 4020	Sweden	(46) 8-603 12 00
Greece	(30) 1-342 60 76	Switzerland	(41) 52-396 31 31
Hungary	(36) 1-371 1343	Turkey	(90) 212 221 15 12
Ireland	(351) 1-403 9000	United Kingdom	(44) 1908-56 38 88

*Websites

SMC Corporation	www.smcworld.com
SMC Europe	www.smceu.com